

SISTEMAS DE CARPINTERIA

**DOMO114F**

Alta Prestación

LISTADO DE PERFILES

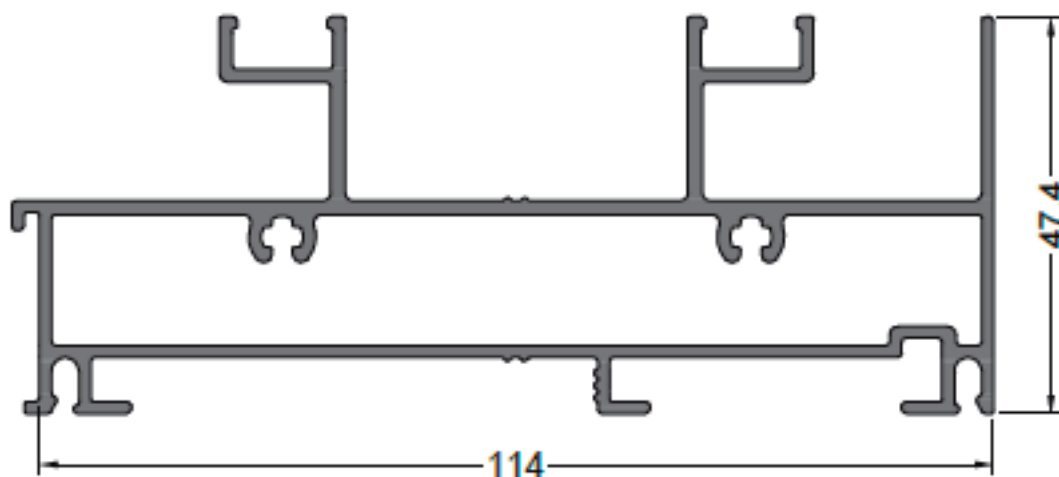

<b>14263</b>
1.857 Kg/m

CORREDIZA MARCO  
UMBRAL / DINTEL

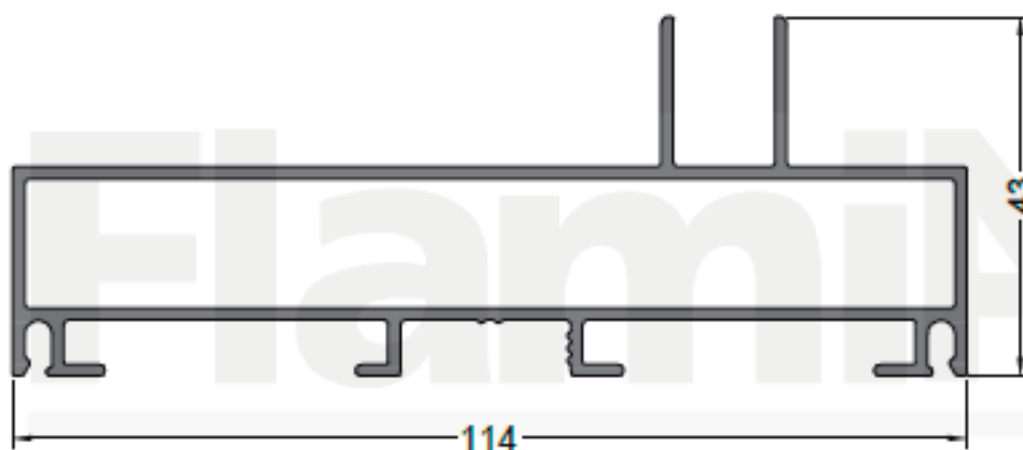

<b>14262</b>
1.352 Kg/m

CORREDIZA MARCO  
JAMBA

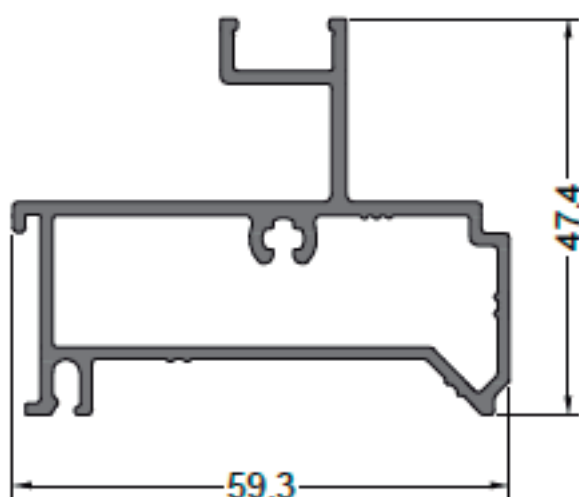

<b>14283</b>
0.924 Kg/m

CORREDIZA MARCO  
1 GUIA UMBRAL / DINTEL

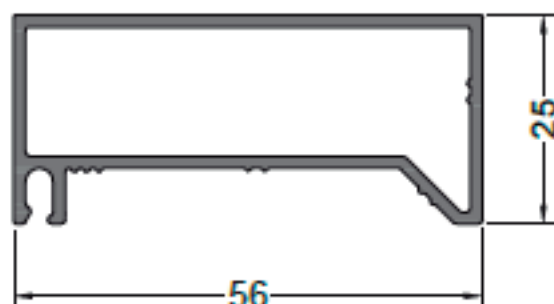

<b>14284</b>
0.639 Kg/m

CORREDIZA MARCO  
1 GUIA JAMBA

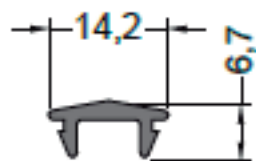

**13214**  
0.100 Kg/m  
CORREDIZA  
GUIA

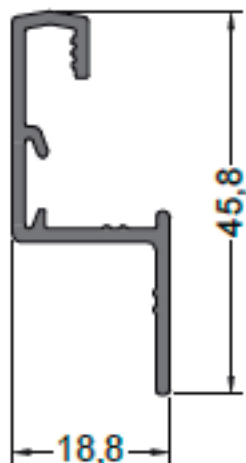

**14264**  
0.350 Kg/m  
CORREDIZA GUIA  
MOSQUITERO

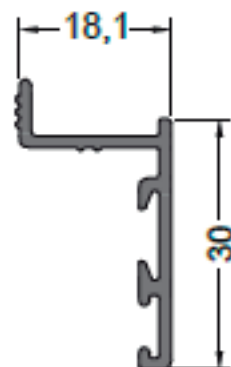

**14243**  
0.254 Kg/m  
TAPAJUNTAS RECTO  
30 mm.

Flamini  
alu sistemas

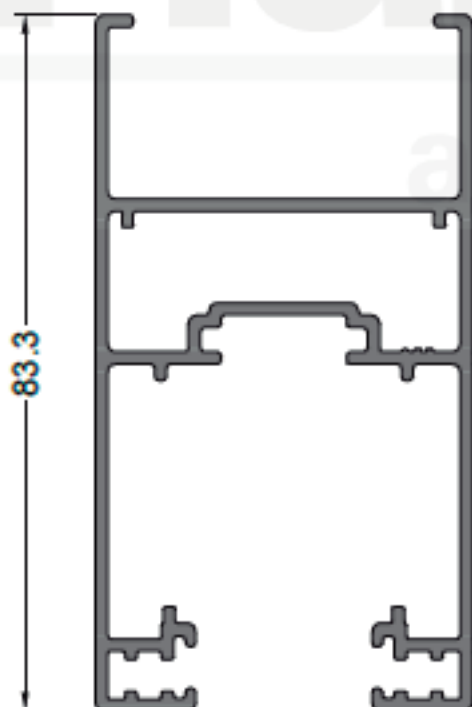

**14270**  
1.301 Kg/m  
CORREDIZA HOJA  
DVH

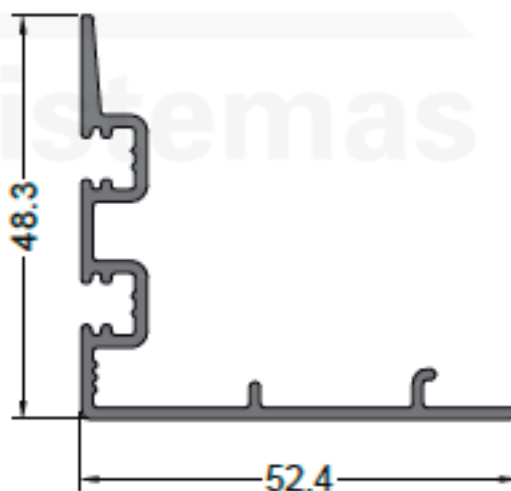

**14271**  
0.543 Kg/m  
CORREDIZA HOJA  
ENCUENTRO

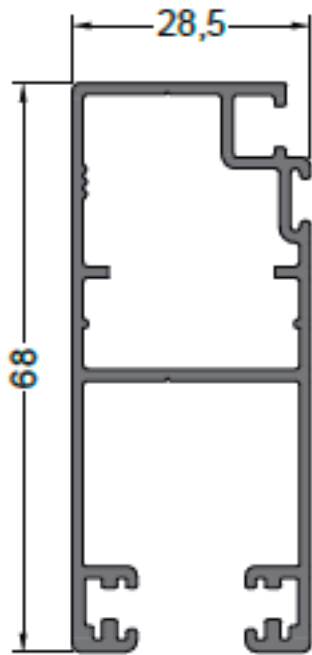

**14062**  
0.888 Kg/m

CORREDIZA MOSQUITERO  
HOJA

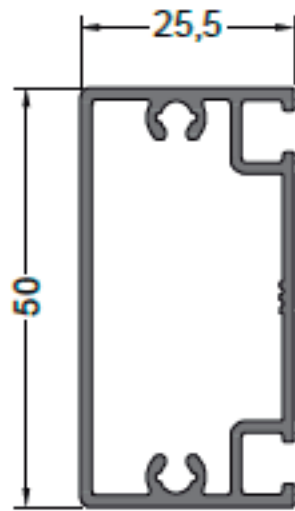

**14063**  
0.659 Kg/m

CORREDIZA MOSQUITERO  
TRAVESANO

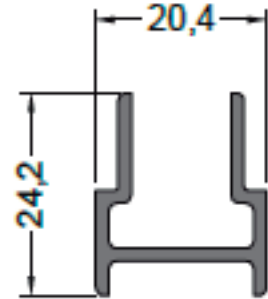

**11747**  
0.288 Kg/m

CORREDIZA ENCUENTRO  
4 HOJAS

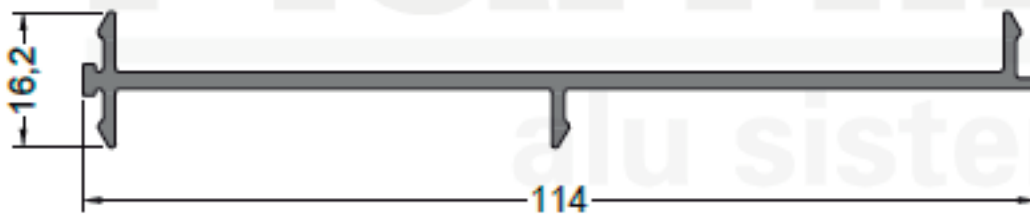

**99346**  
0.708 Kg/m

ACOPLE 180°

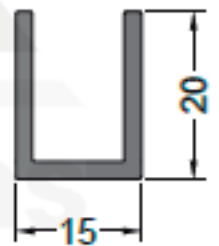

**99893**  
0.275 Kg/m

PERFIL U 15x20 mm.

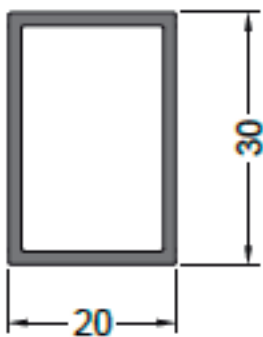

**99892**  
0.405 Kg/m

TUBO RECTANGULAR  
20 x 30 mm.

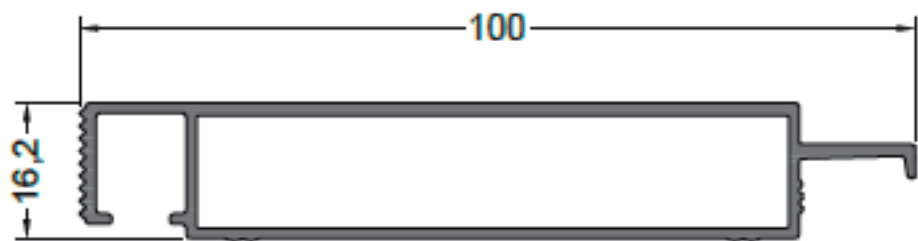

**13934**  
0.900 Kg/m

PREMARCO  
100 mm.

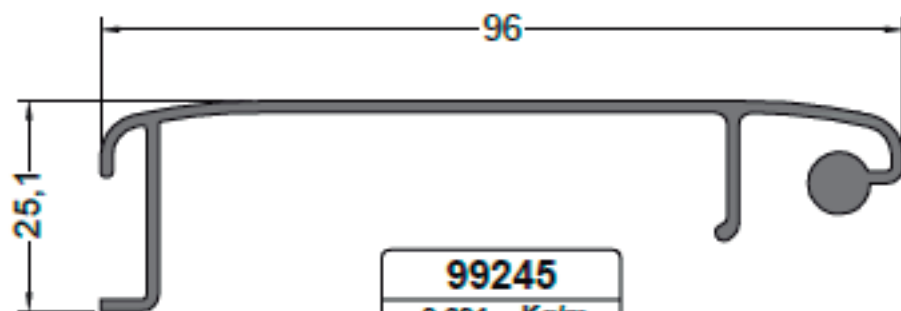

**99245**  
0.631 Kg/m

CORTINA TAPACINTA  
96 mm.

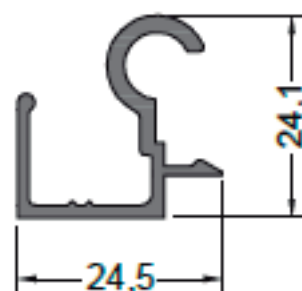

**99254**  
0.303 Kg/m

CORTINA BISAGRA

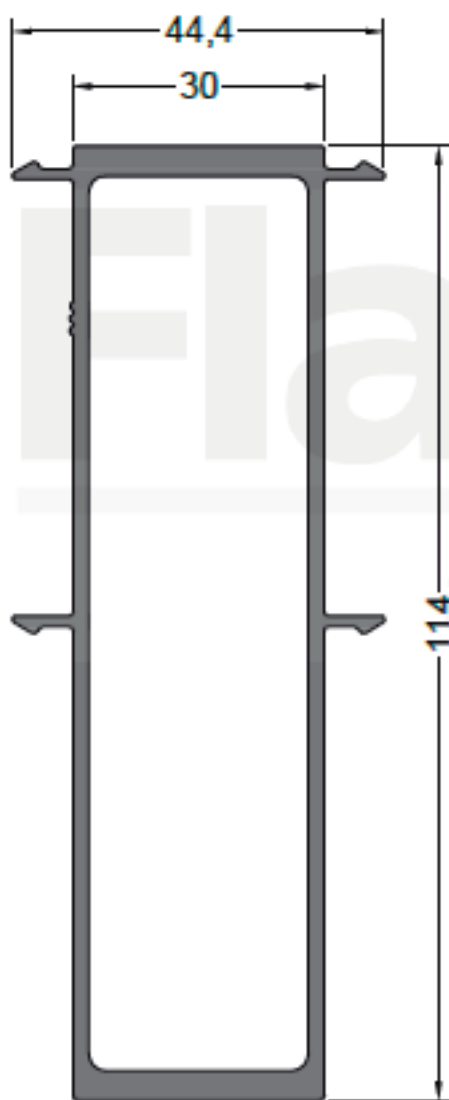

**14316**  
1.780 Kg/m

ACOPLE REFORZADO  
180°

Flamini  
alu sistemas

# SISTEMAS DE CARPINTERIA

## DOMO114F

Alta Prestación

VENTANA CORREDIZA

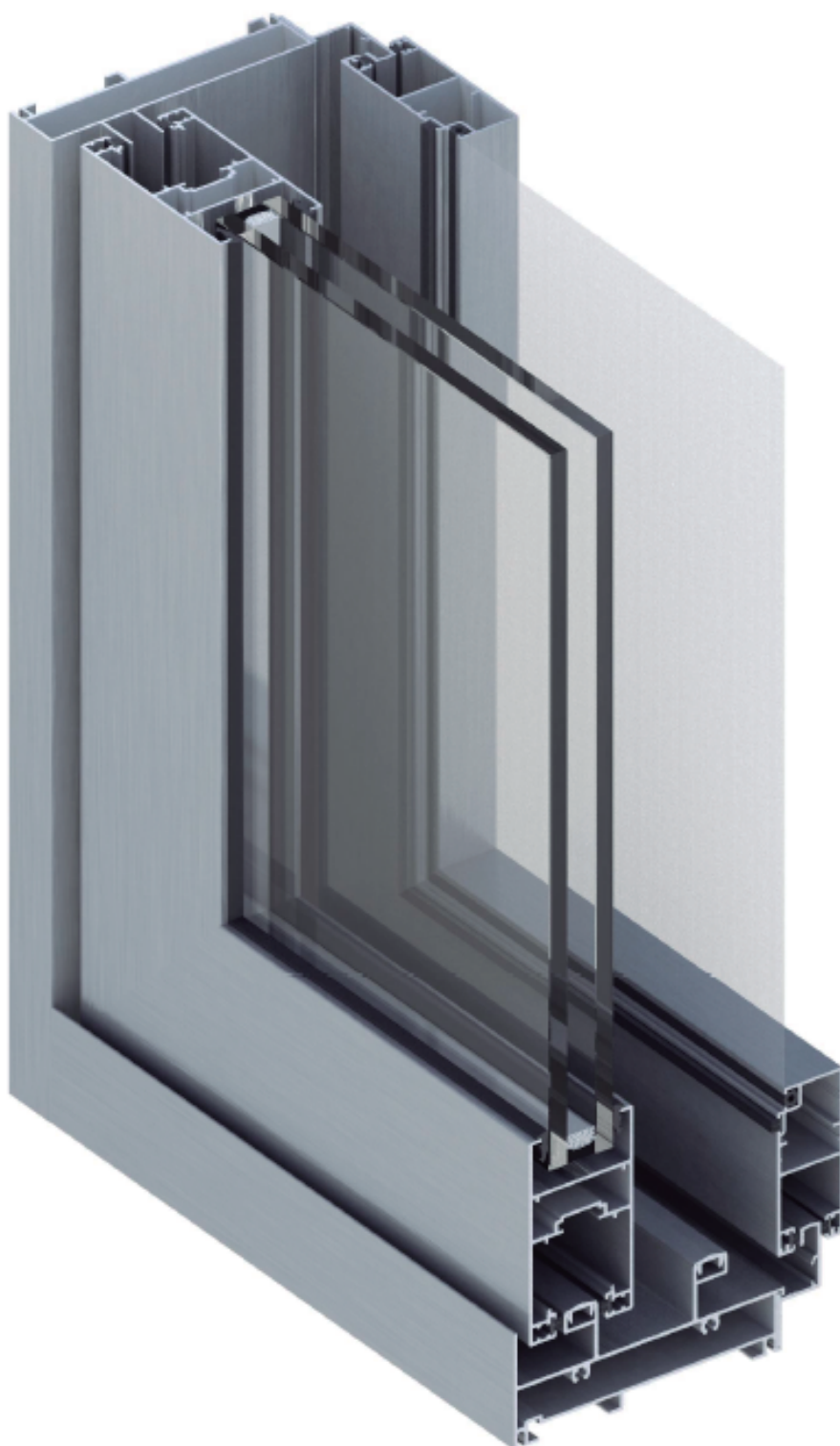

Corte horizontal ventana corrediza 2 y 4 hojas  
Marco 2 guías.

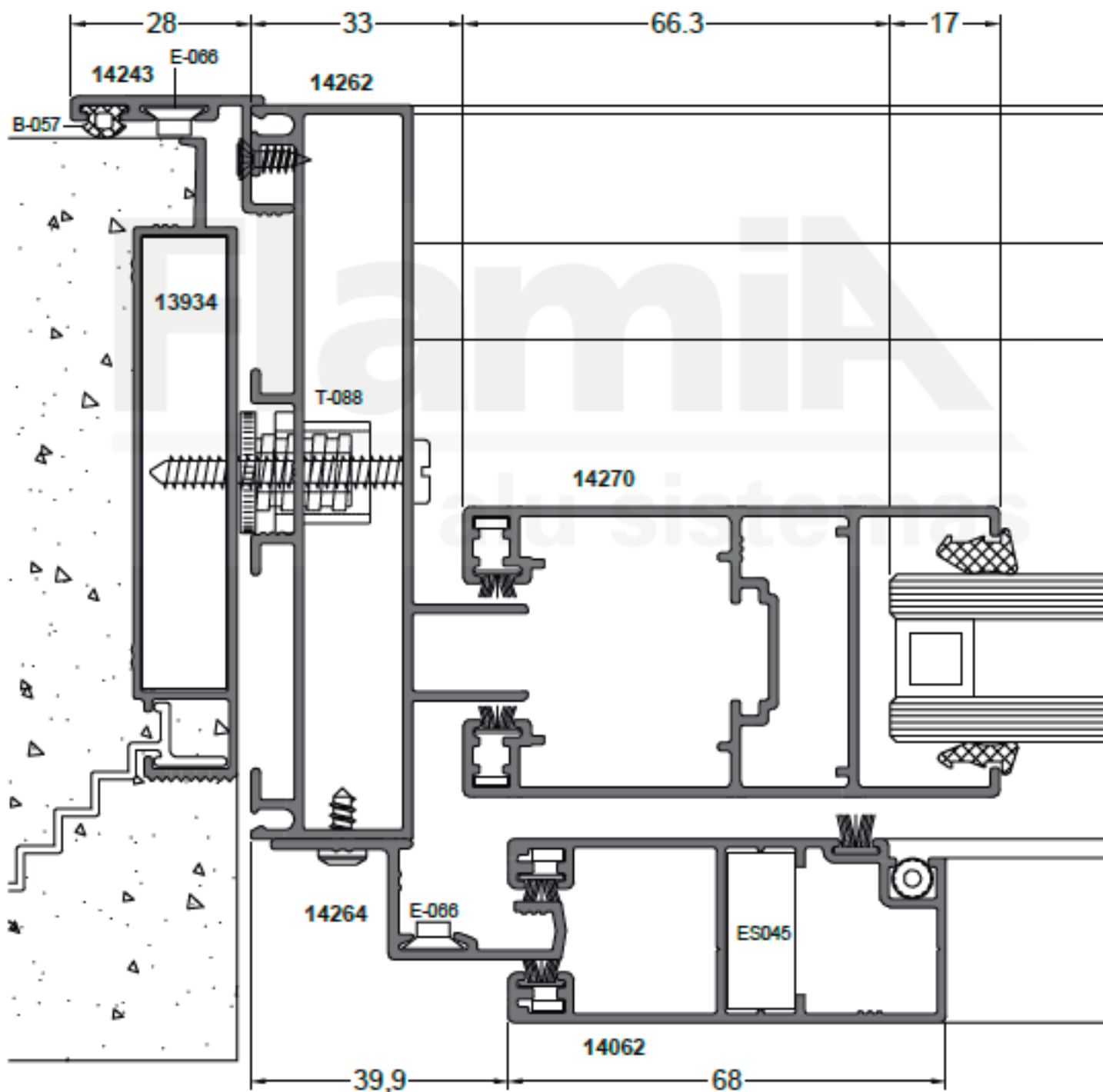
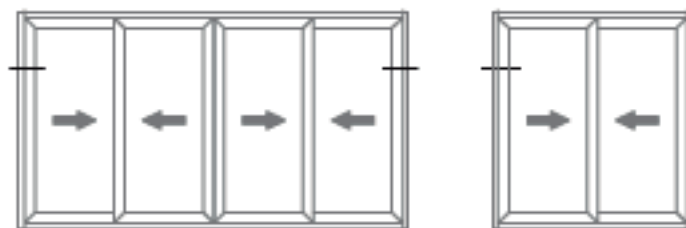

Corte horizontal ventana corrediza 2 y 4 hojas  
Marco 2 guías.

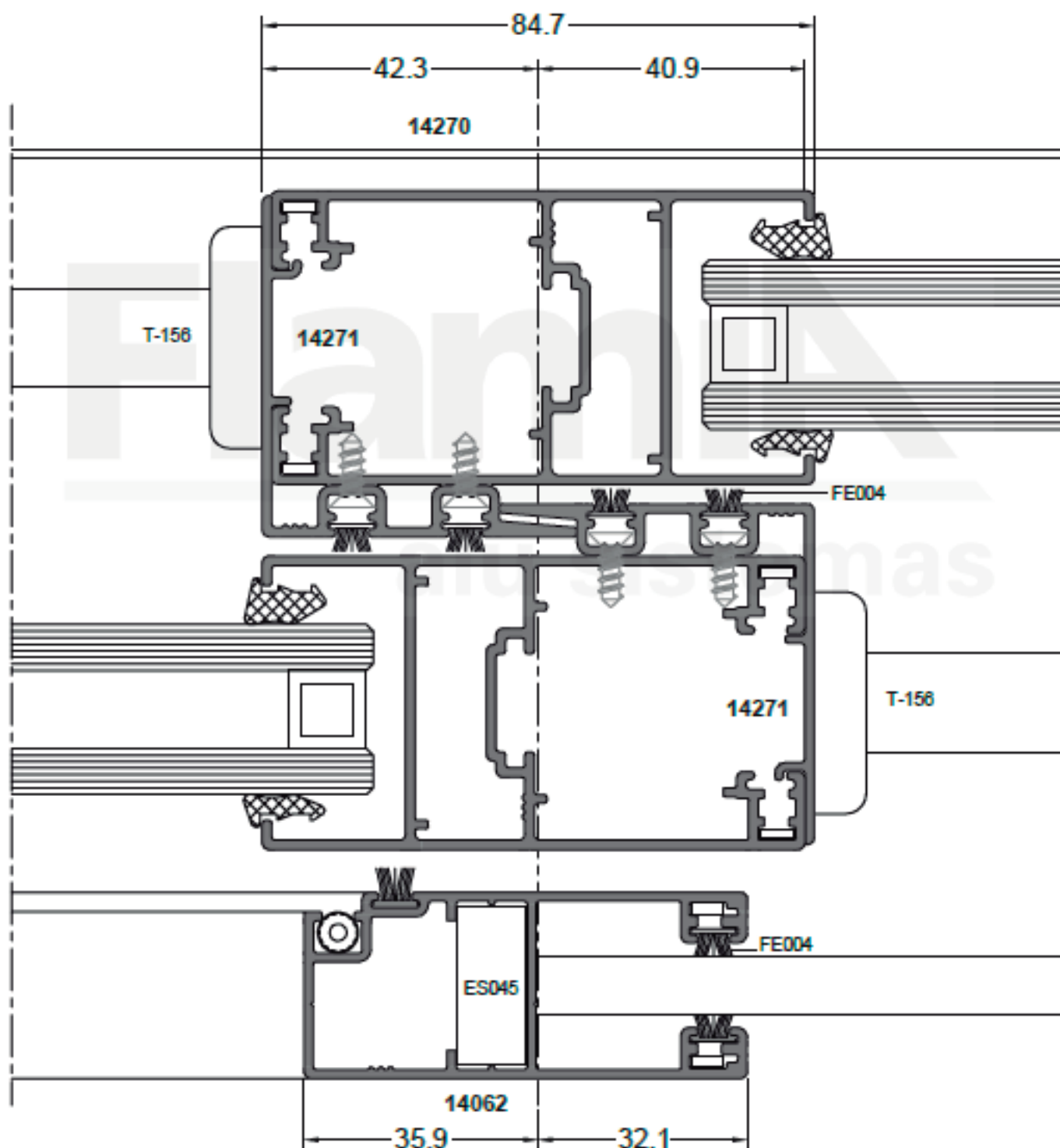
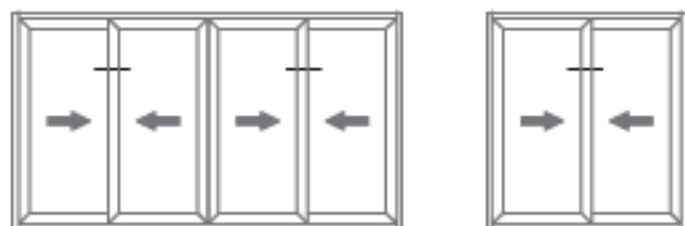



Corte horizontal ventana corrediza 4 hojas  
Marco 2 guías.

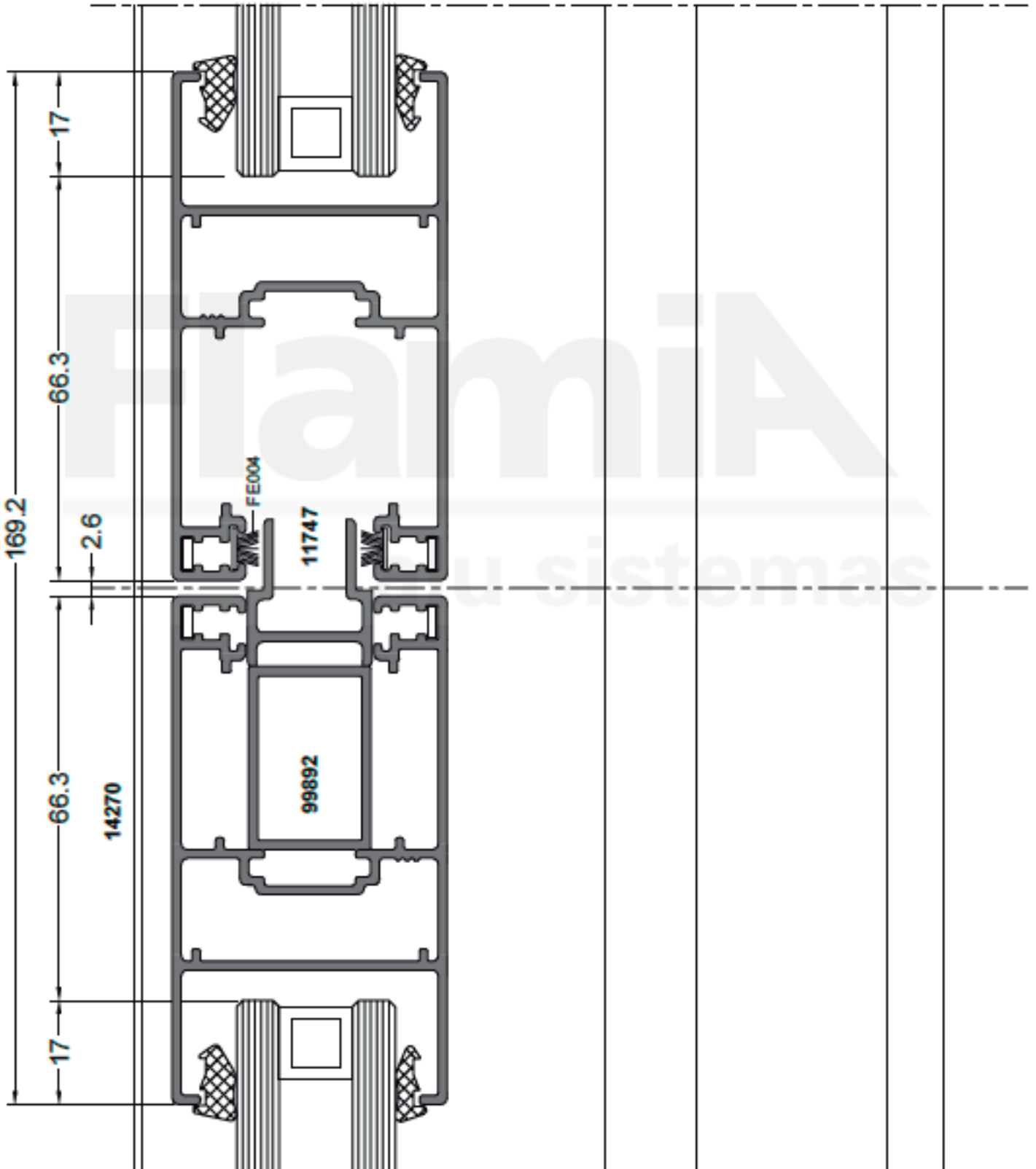
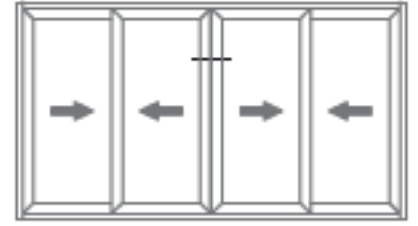

Corte horizontal ventana corrediza 2 hojas  
Marco 2 guías.

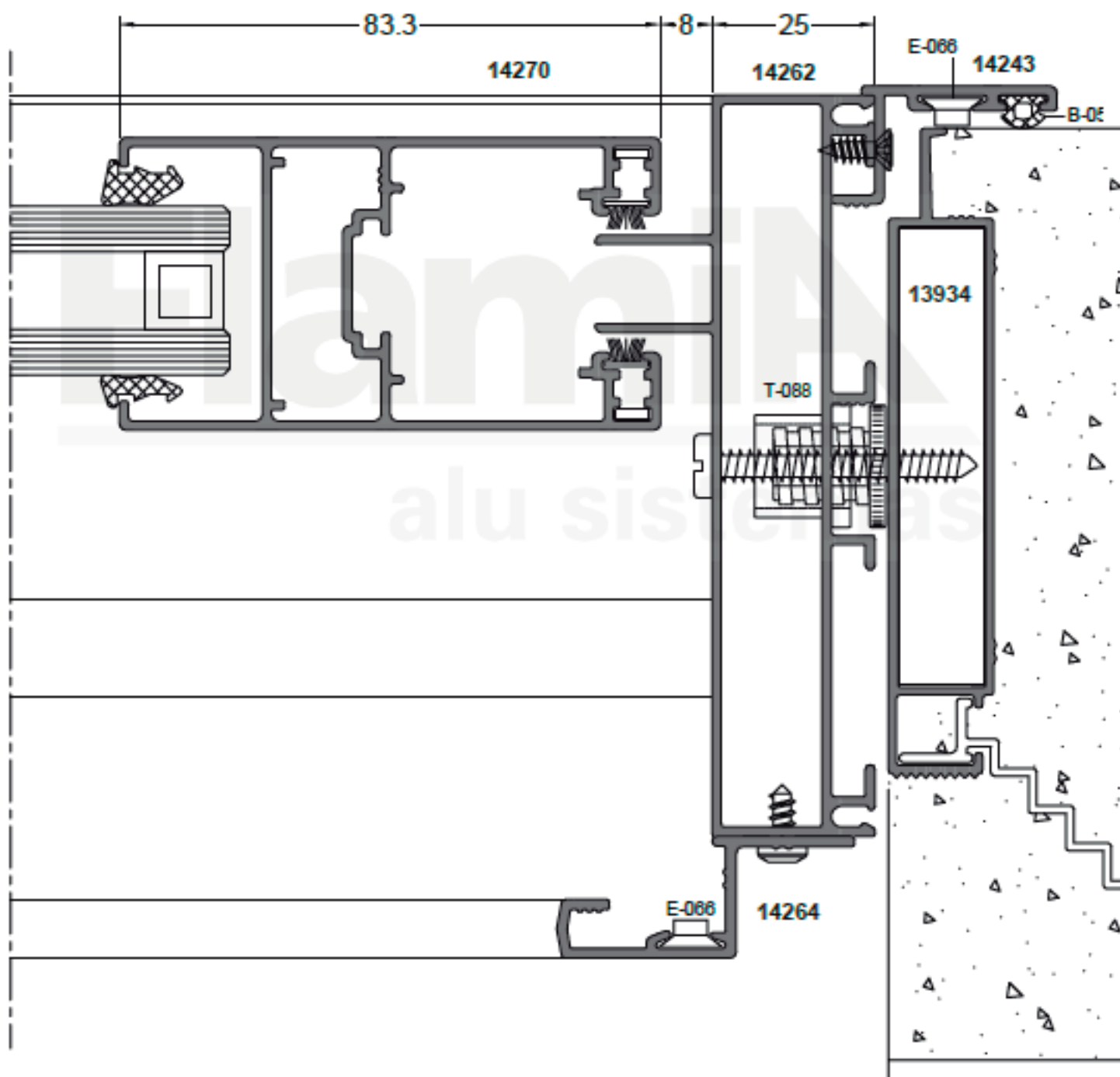

Corte vertical ventana corrediza 2 y 4 hojas  
Marco 2 guías.

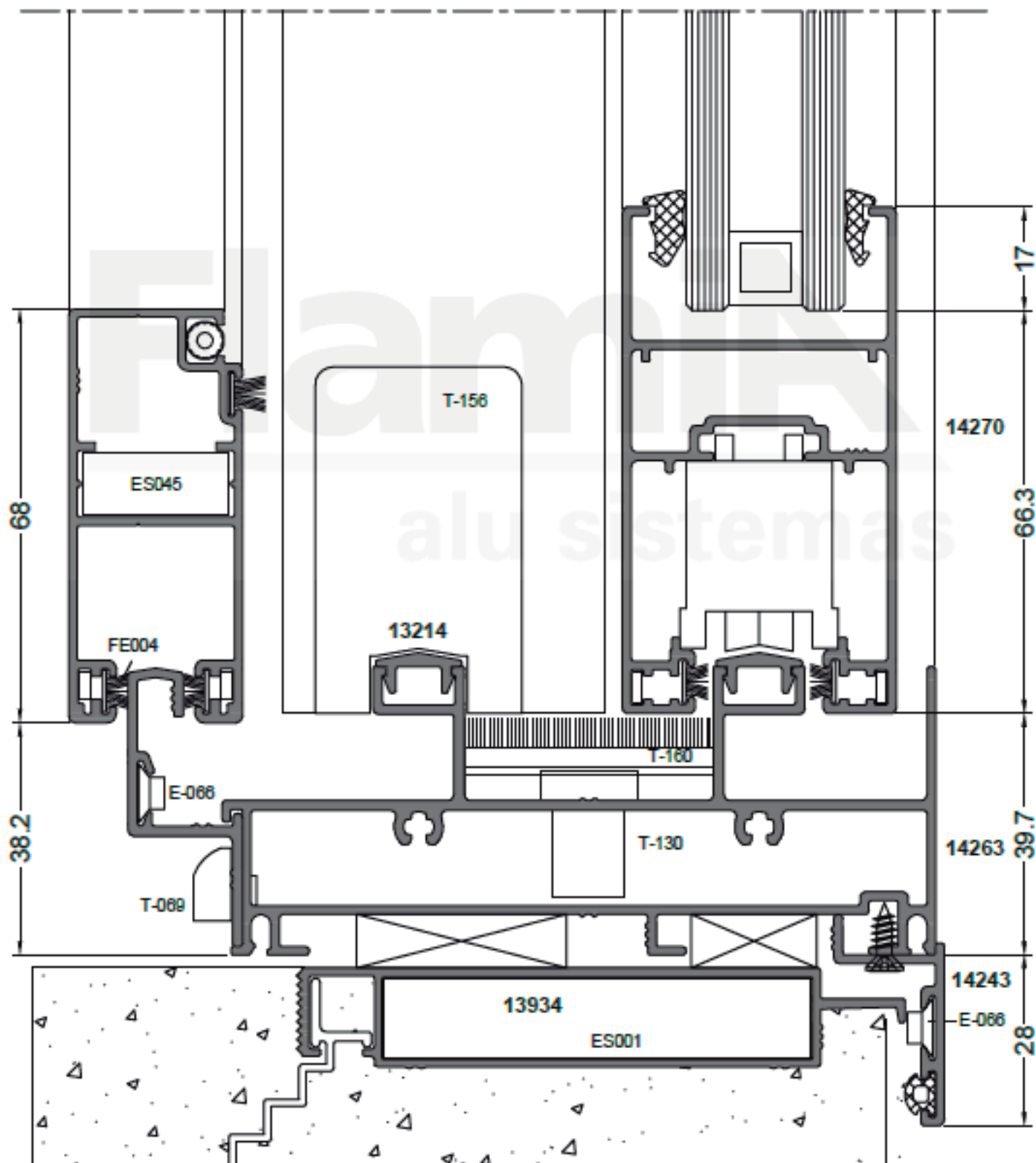
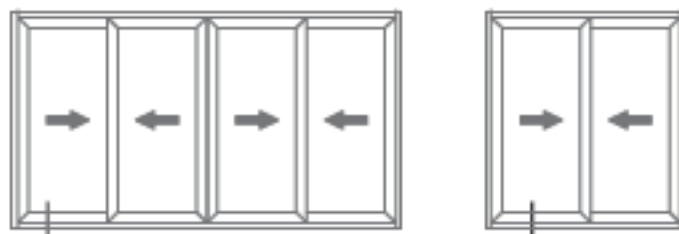

## Corte vertical ventana corrediza 2 y 4 hojas Marco 2 guías.

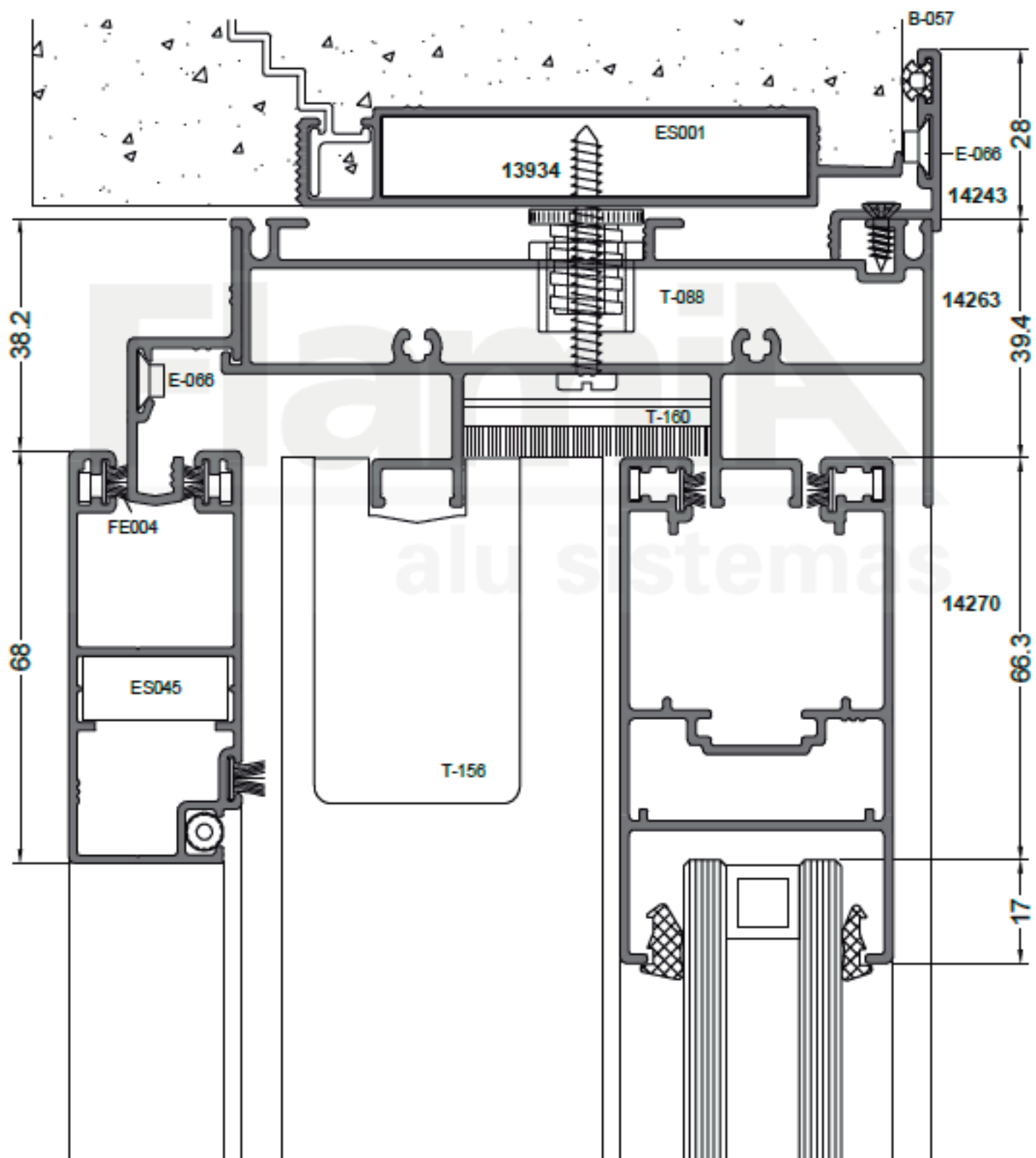
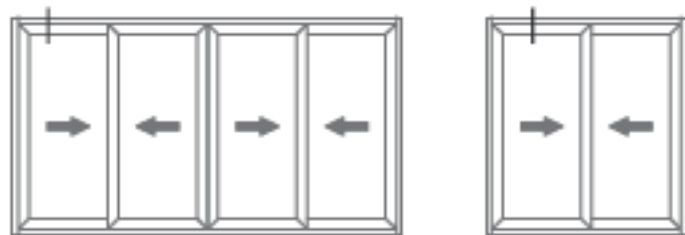

Corte horizontal acople 180°  
Marco 2 guías.

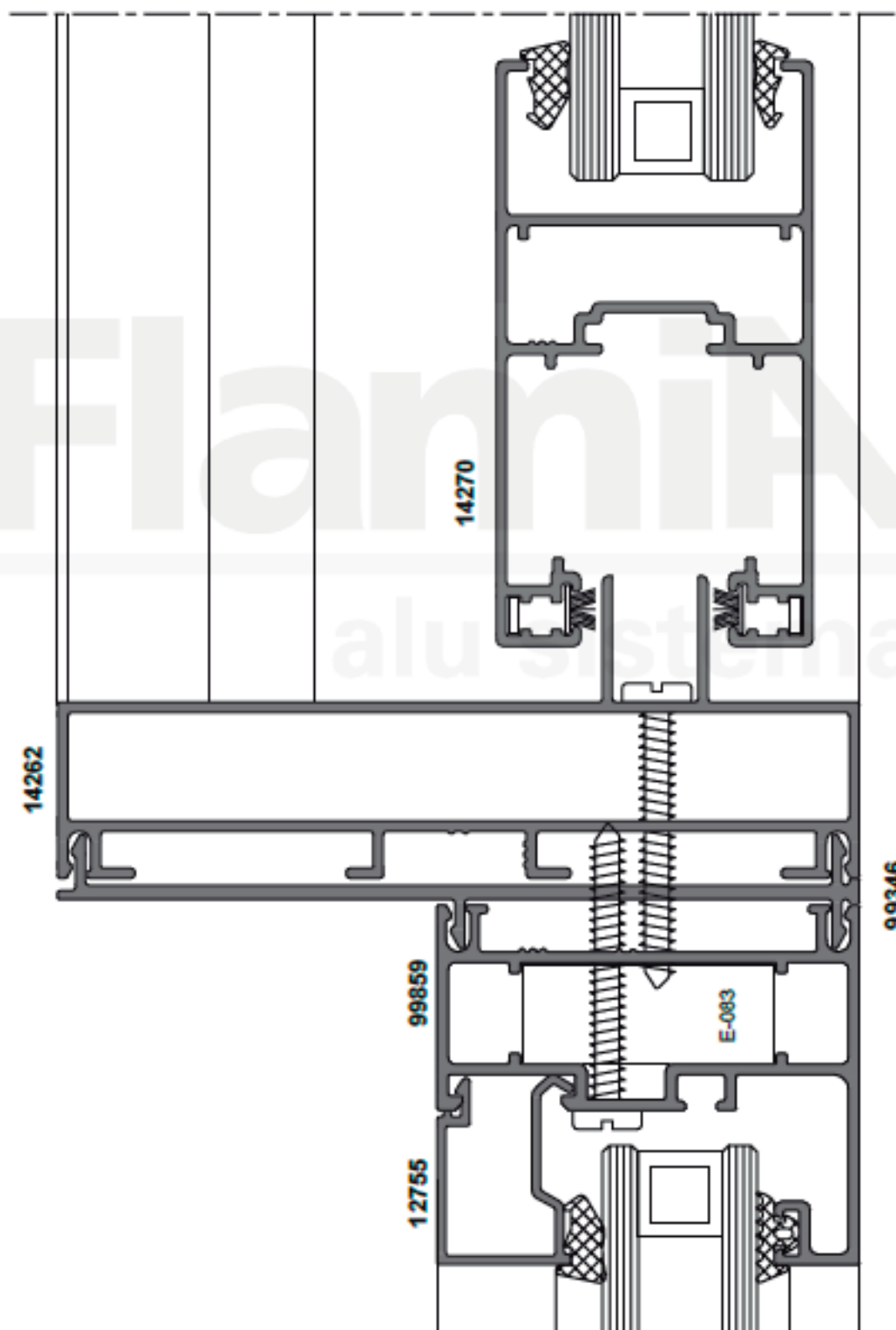
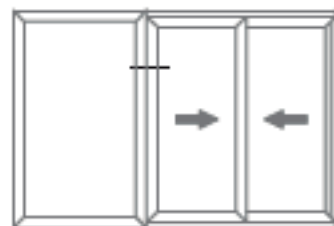

## Corte horizontal acople reforzado 180° Marco 2 guías.

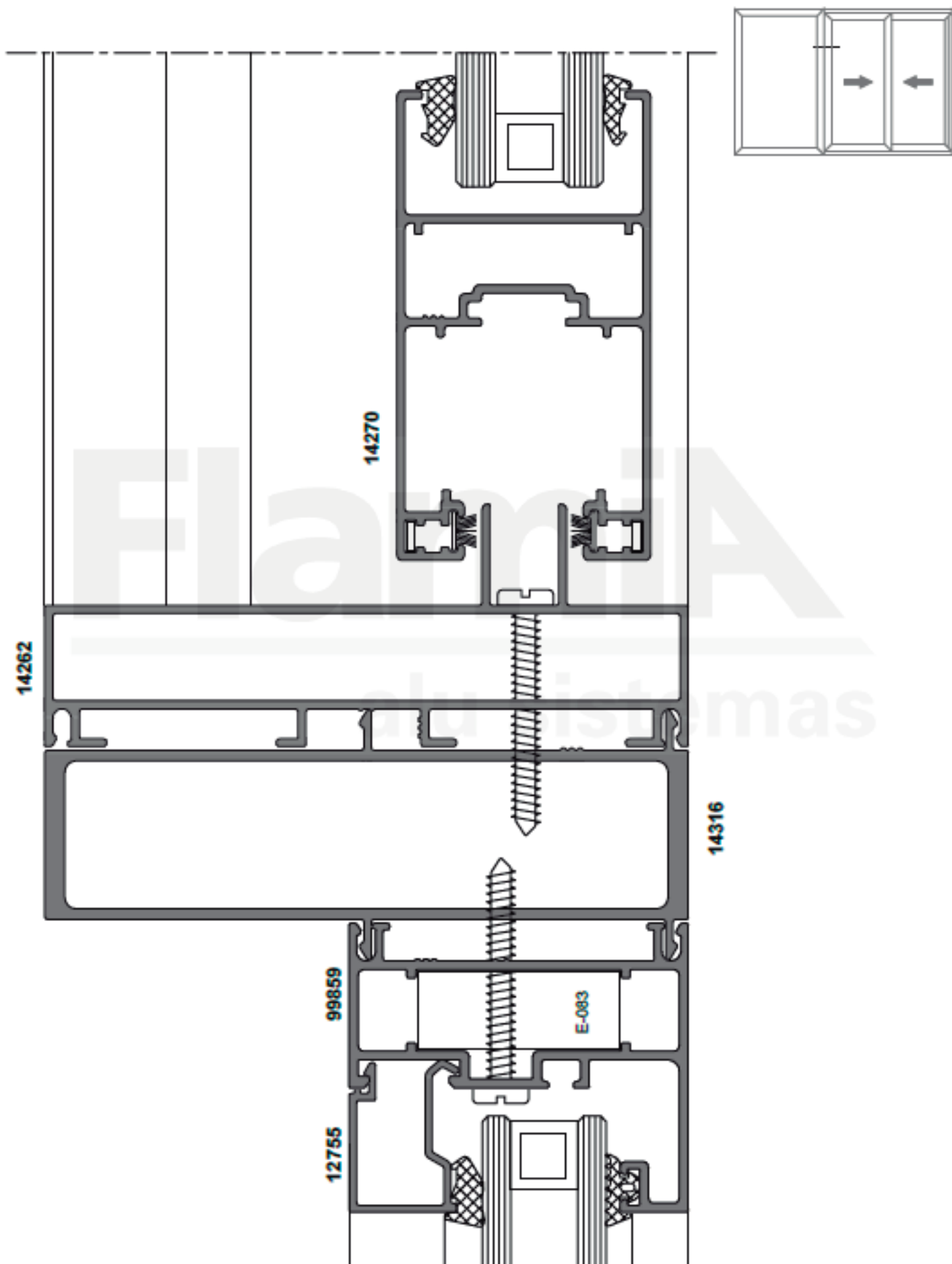

Corte horizontal

Tapajuntas atornillado (ver detalle de mecanizado 04.12 y 04.13)

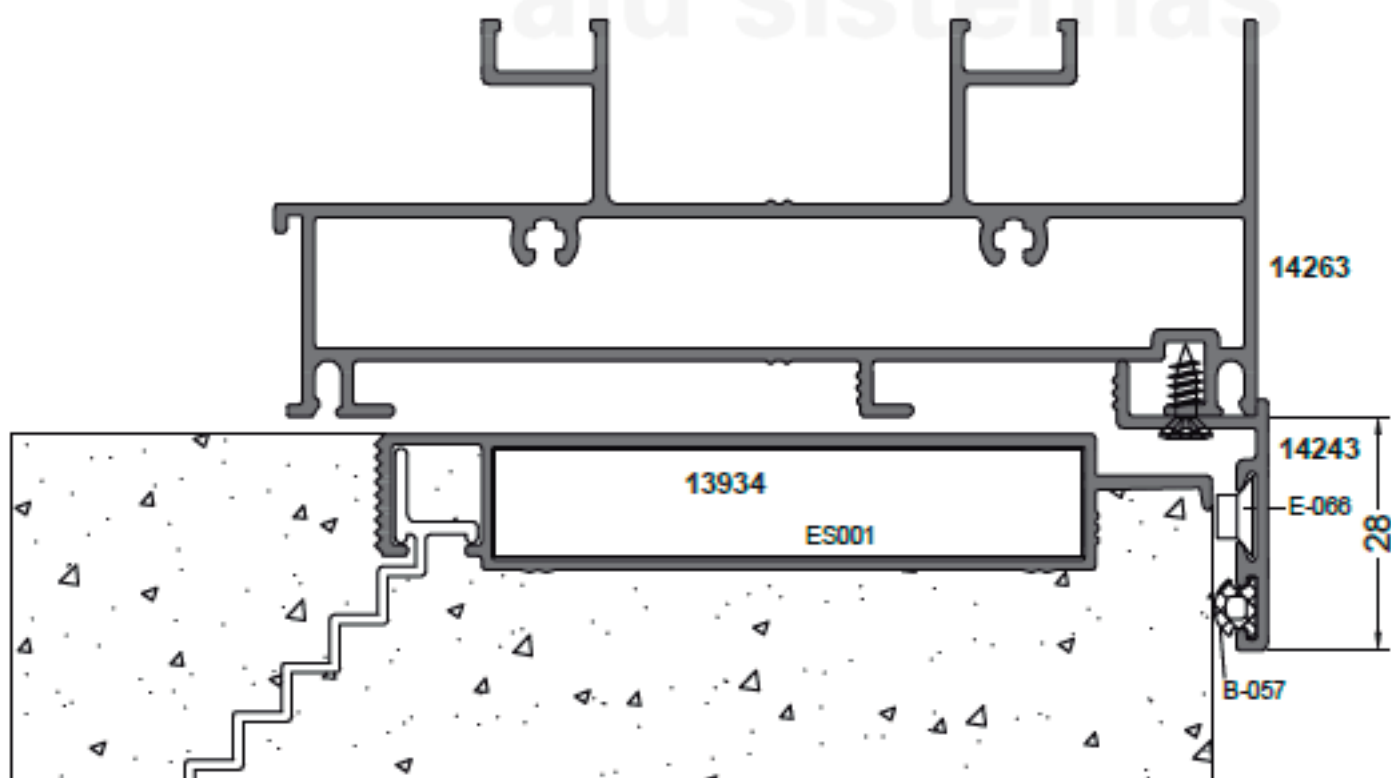
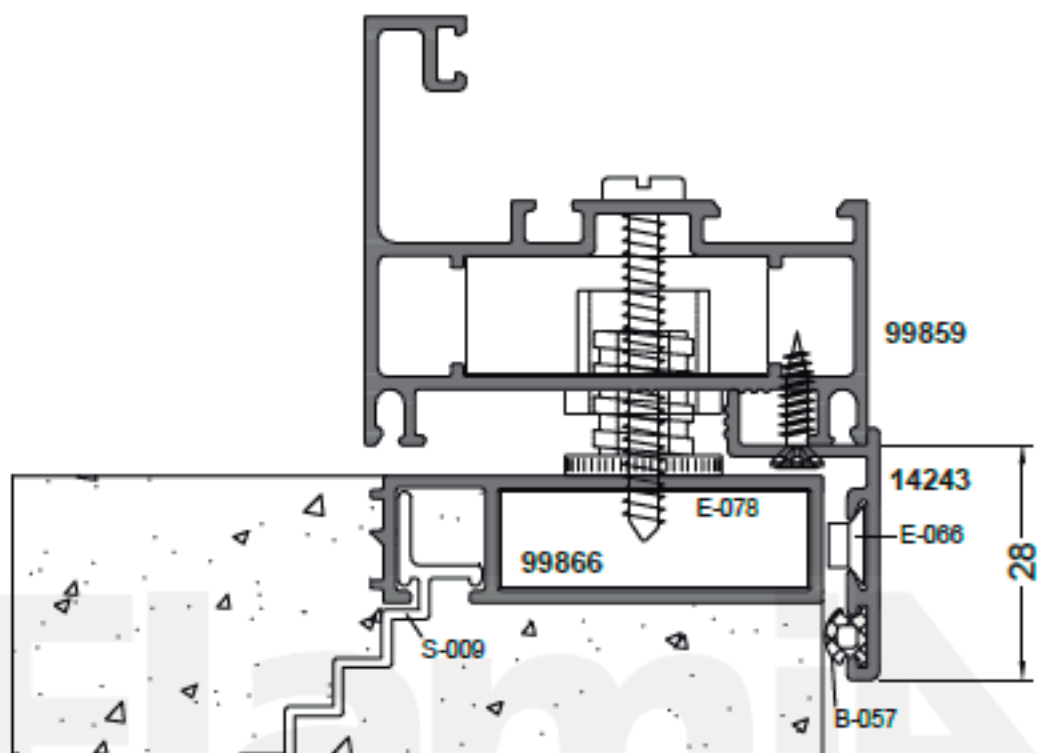

Corte horizontal ventana corrediza 3 y 6 hojas  
Marco 2 guías con guía aplicada

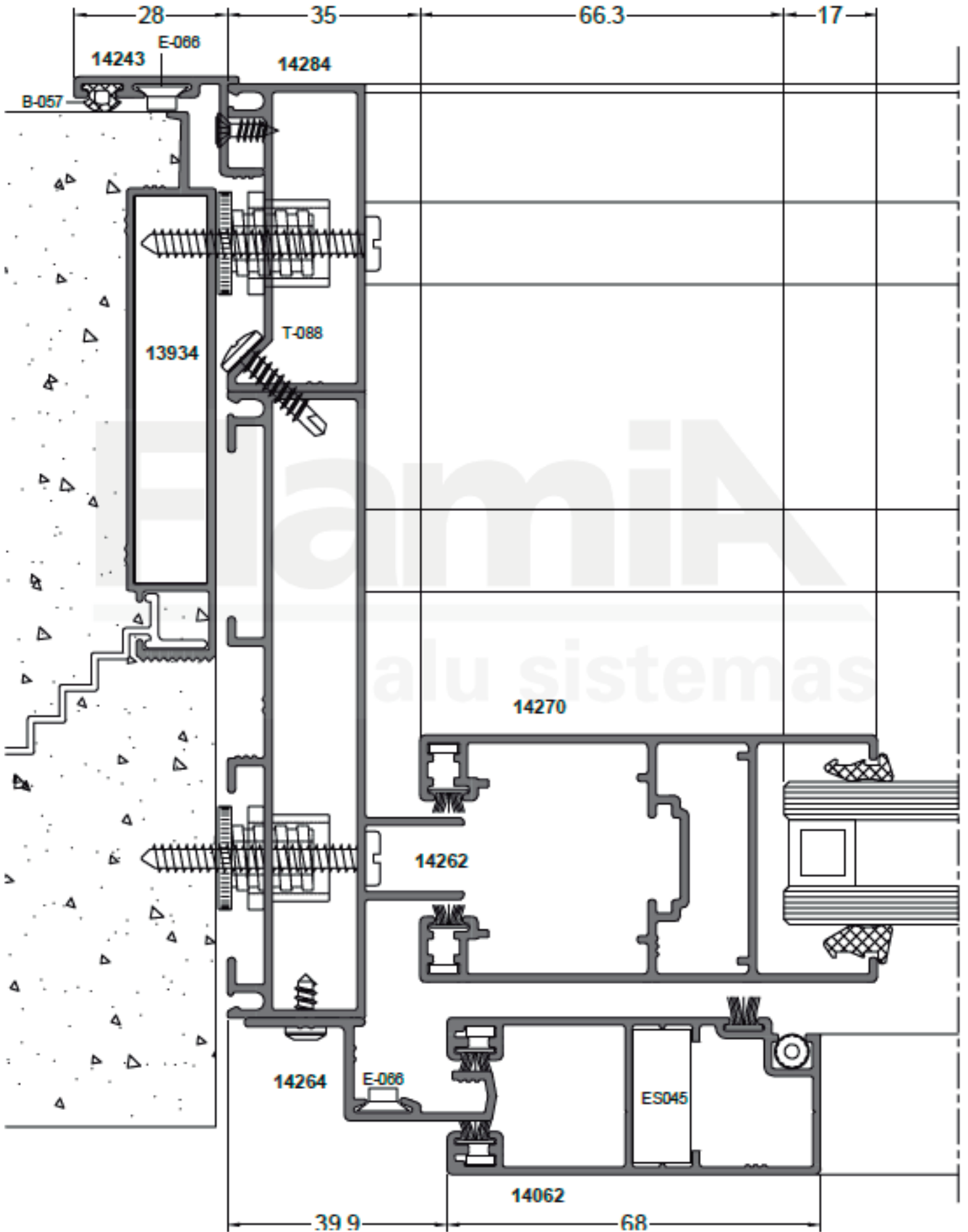
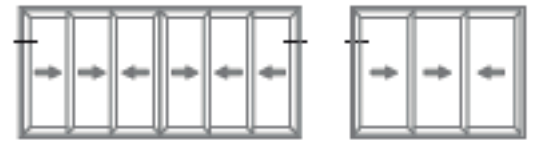



Corte horizontal ventana corrediza 3 y 6 hojas  
 Marco 2 guías con guía aplicada

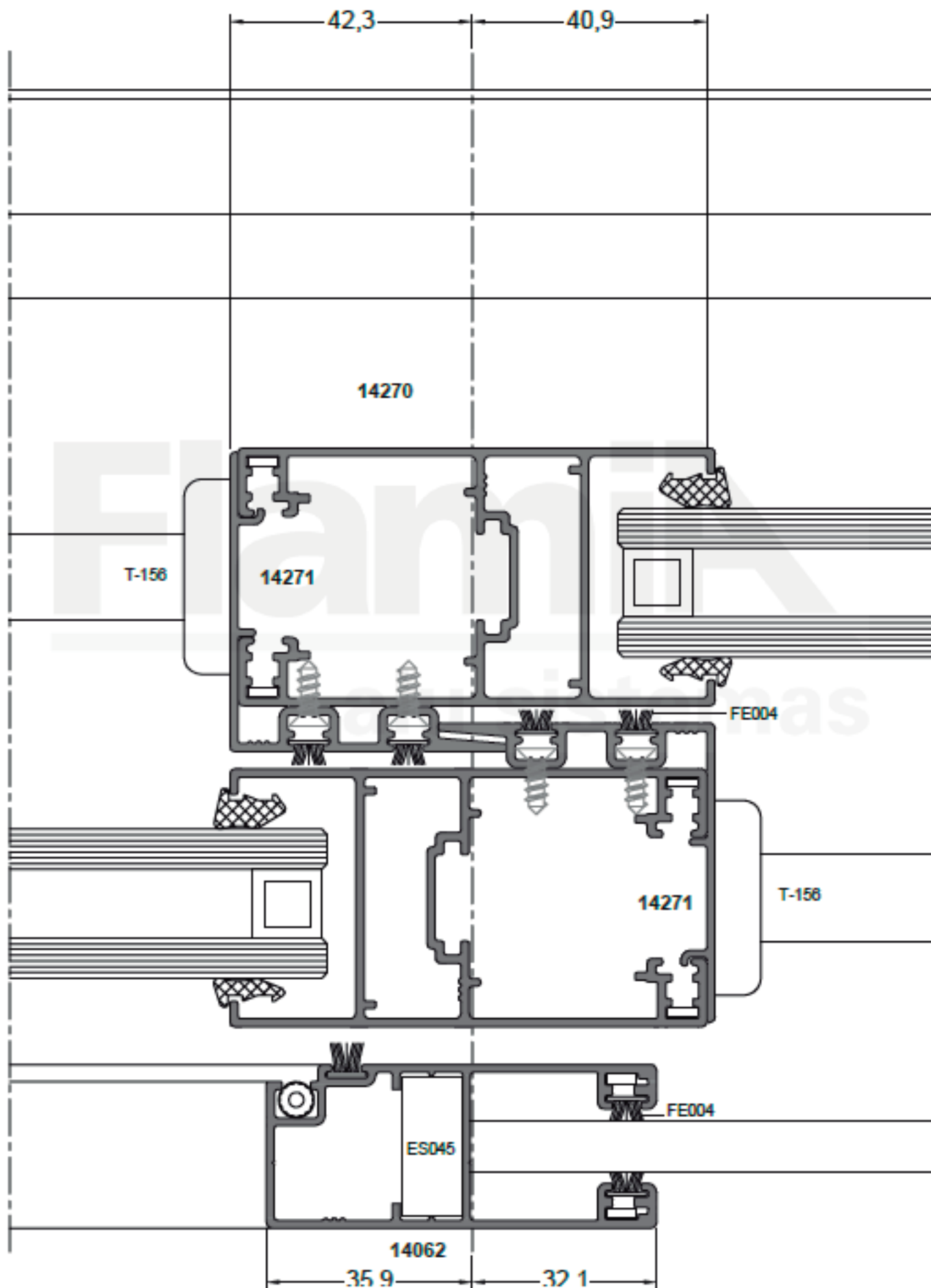

Corte horizontal ventana corrediza 3 y 6 hojas  
Marco 2 guías con guía aplicada

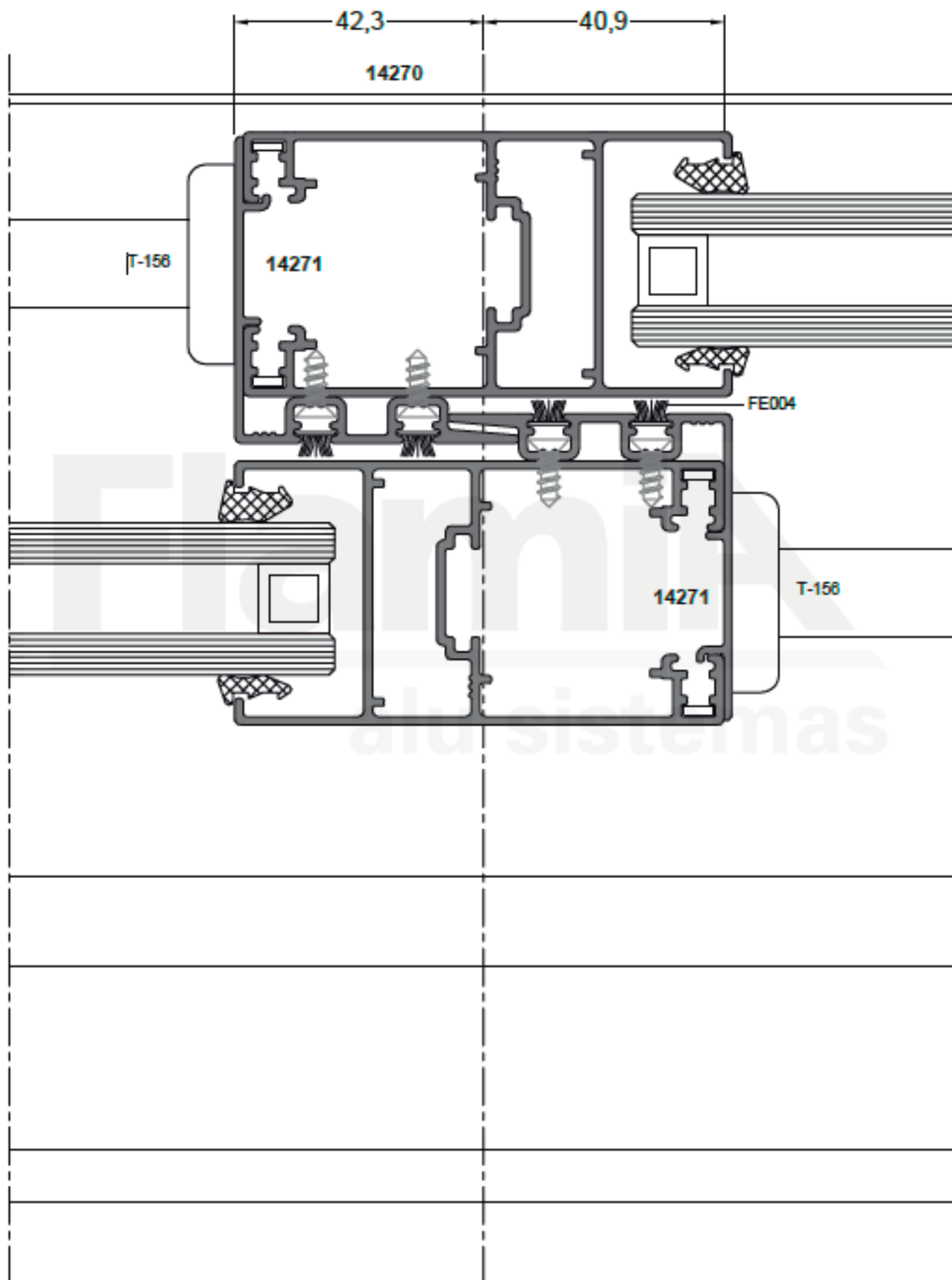

Corte horizontal ventana corrediza 3 y 6 hojas  
Marco 2 guías con guía aplicada

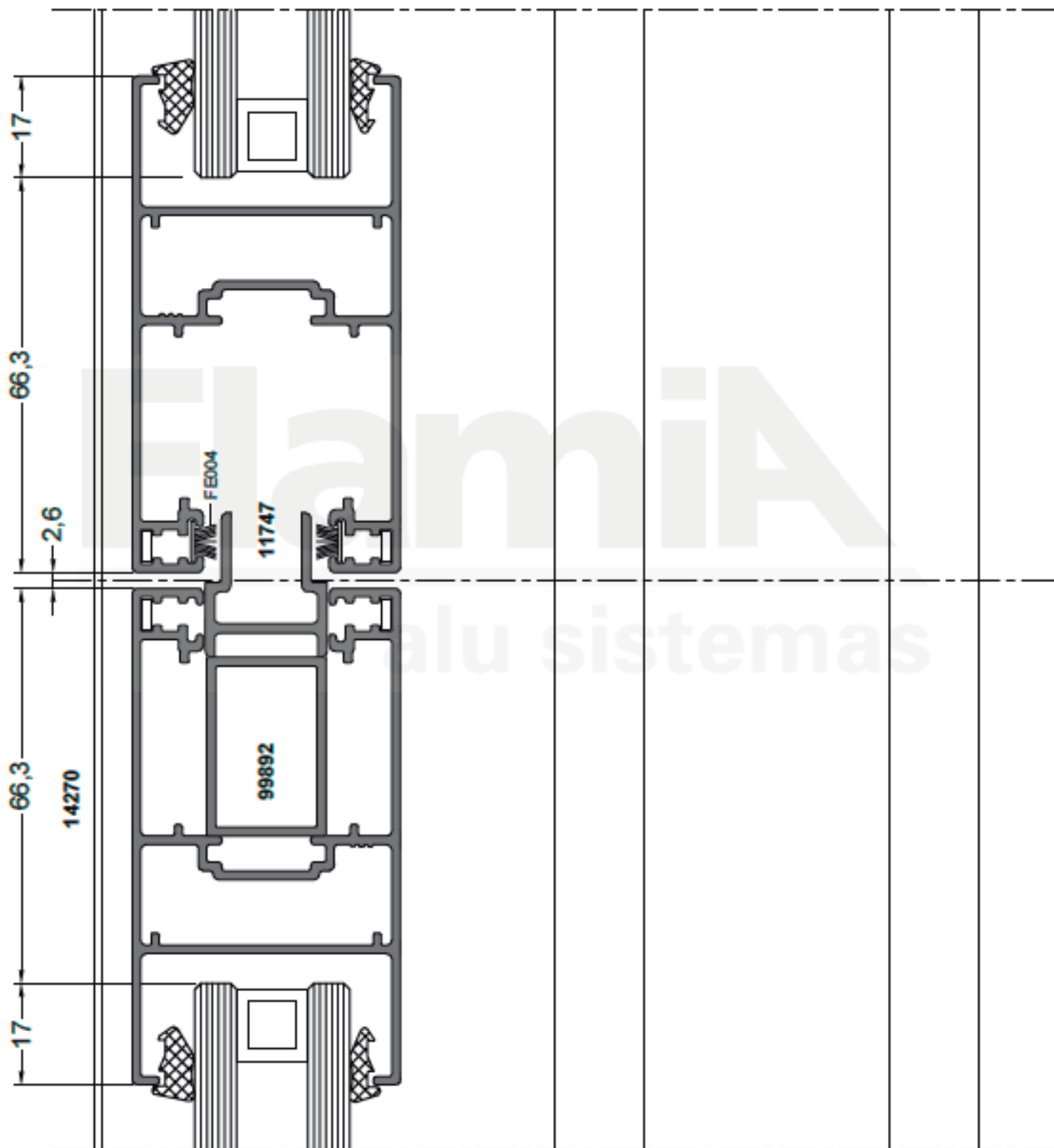

Corte vertical ventana corrediza 3 y 6 hojas  
Marco 2 guías con guía aplicada

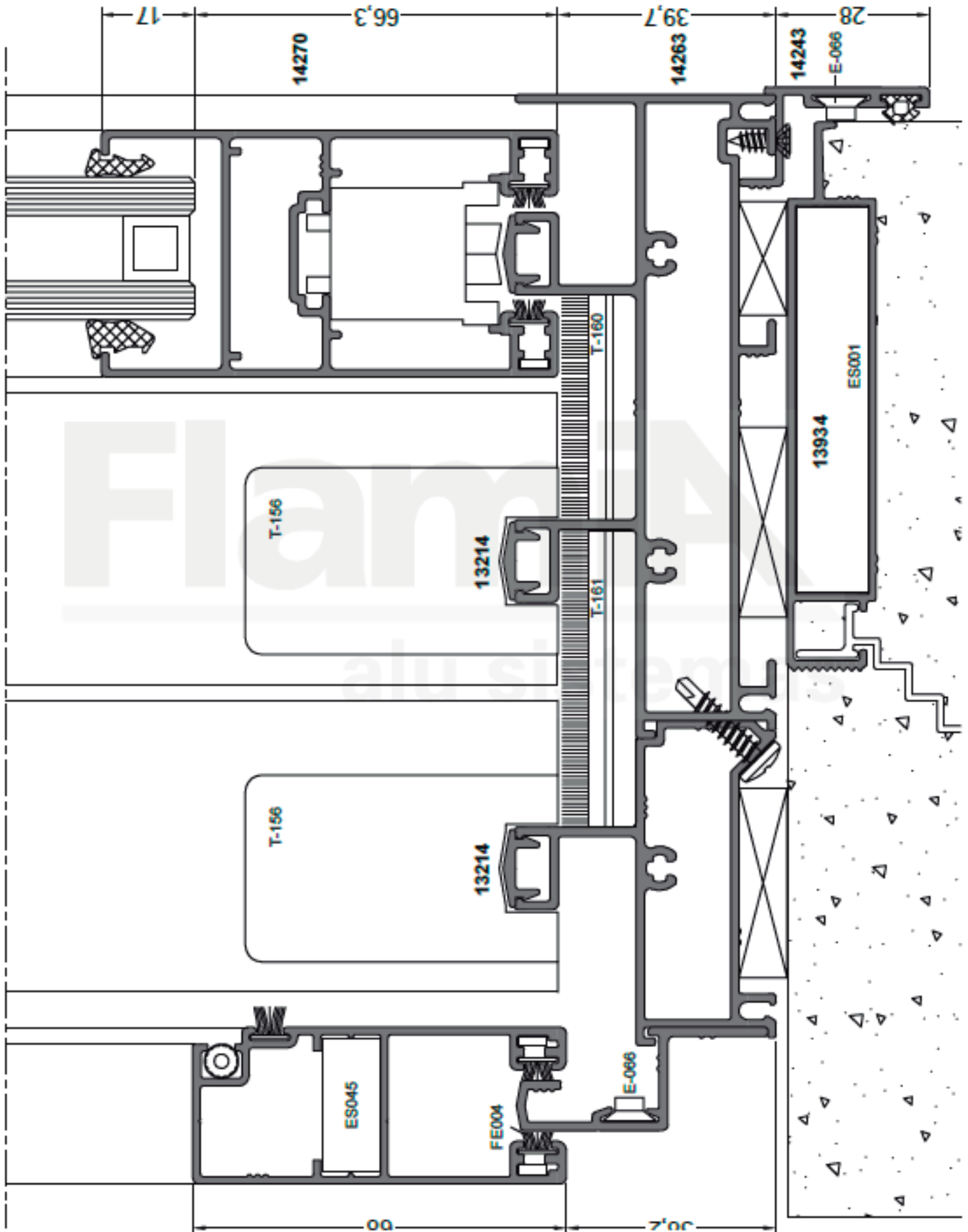



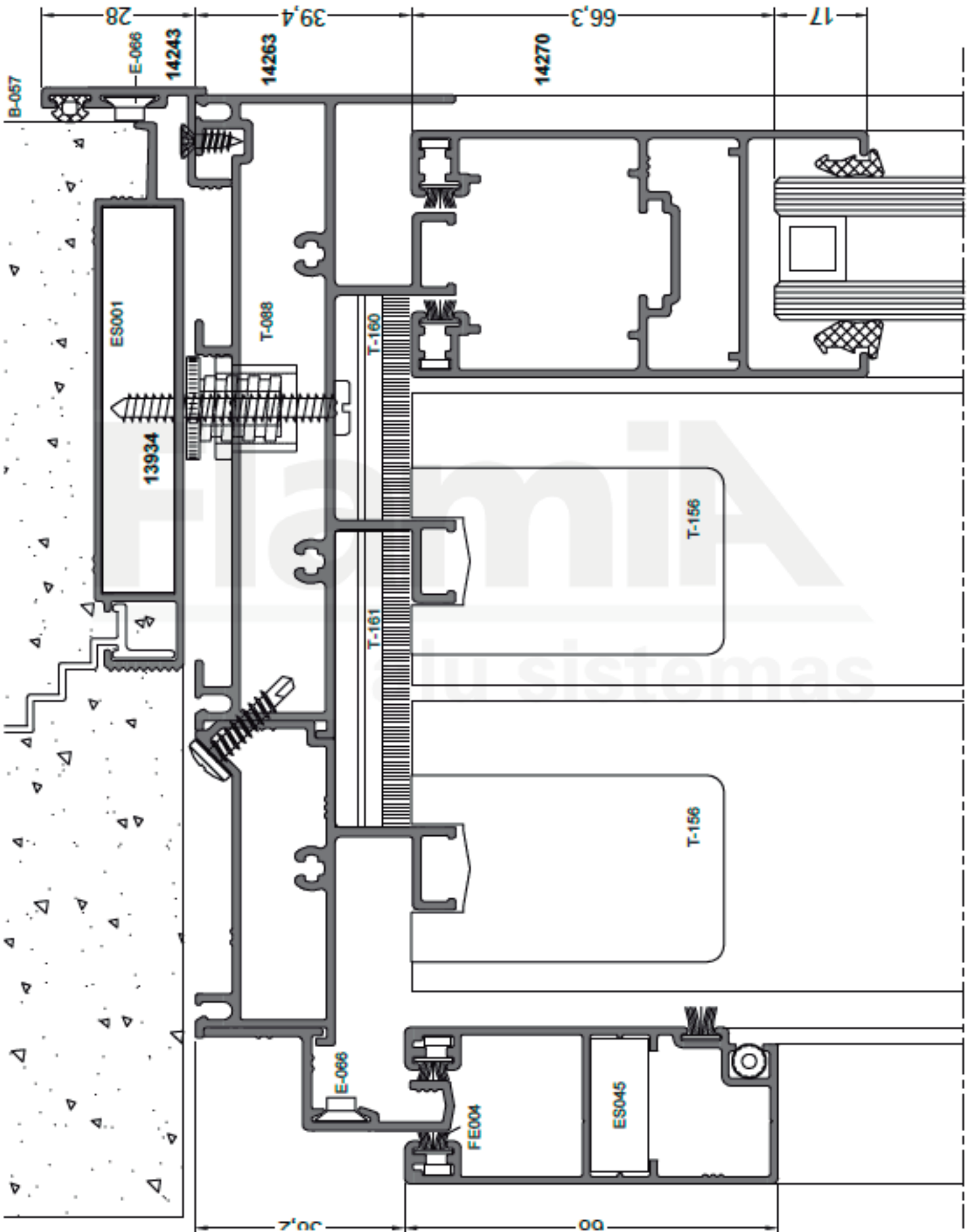



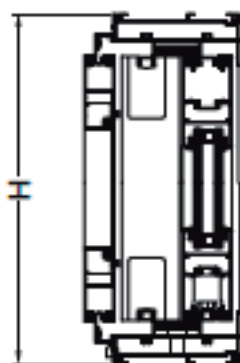
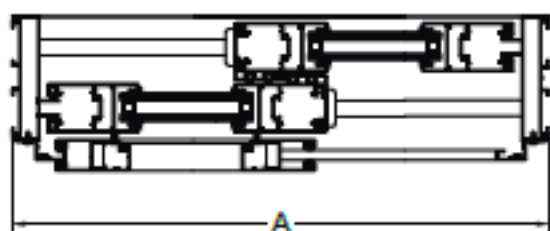



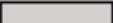











Corte vertical ventana corrediza 3 y 6 hojas  
Marco 2 guías con guía aplicada



## Listado de perfiles marco 2 guías

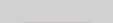

**Vidrio :**  
**Ancho = Ancho de la hoja - 133**  
**Alto = Alto de la hoja - 133**

Código	Perfil	Descripción	Peso (kg/m)	Corte	2 hojas				4 hojas			
					Horizontal		Vertical		Horizontal		Vertical	
					Cant.	Medida	Cant.	Medida	Cant.	Medida	Cant.	Medida
14263		Marco umbral 2 guías	1.857		2	A - 50			2	A - 50		
14262		Marco jamba 2 guías	1.352				2	H			2	H
13214		Guía	0.100		2	A - 68			1	A-50		
									1	A-86		
14270		Hoja DVH	1.301		4	A/2 + 9	4	H - 79	8	A/4+25	8	H - 79
14271		Encuentro de hoja	0.543				2	H - 79			4	H - 79
11747		Encuentro 4 hojas	0.288								1	H - 102
99892		Tubo 20x30 mm.	0.405								1	H - 102
14264		Guia mosquitero	0.350		2	A - 6	2	H - 3	2	A - 6	2	H - 3
14062		Mosquitero	0.888		2	A/2 - 8	2	H - 76	4	A/4+8	4	H - 76
14063		Travesaño mosq.	0.659		1	A/2-144			2	A/4-128		
13934		Premarco	0.900		2	A + 40	2	H + 40	2	A + 40	2	H + 40
14243		Tapajunta	0.254		2	A + 56	2	H + 56	2	A + 56	2	H + 56

FORMULA DE CORTE VALIDA UNICAMENTE PARA LA CONSTRUCCION DE UN PROTOTIPO.  
 NO APTA PARA PRODUCCION DE ABERTURAS

## Listado de perfiles marco 2 guías

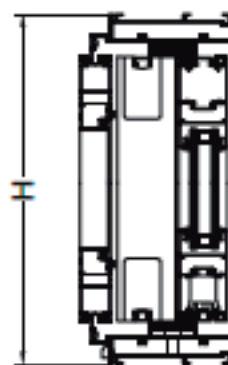

Código	Perfil	Descripción	Peso (kg/m)	Corte	3 hojas lateral a $\frac{1}{2}$			
					Horizontal		Vertical	
					Cant.	Medida	Cant.	Medida
14263		Marco umbral 2 guías	1.857		2	A - 50		
14262		Marco jamba 2 guías	1.352				2	H
13214		Guía	0.100		2	A - 68		
14270		Hoja DVH	1.301		2 4	A/2 + 63 A/4 + 21	4	H - 79
14271		Encuentro de hoja	0.543				4	H - 79
14264		Guía mosquitero	0.350		2	A - 6	2	H - 3
14062		Mosquitero	0.888		4	A/2 + 7	4	H - 76
14063		Travesaño mosq.	0.659		2	A/2 - 129		
13934		Premarco	0.900		2	A + 40	2	H + 40
14243		Tapajunta	0.254		2	A + 58	2	H + 58

### Vidrio :







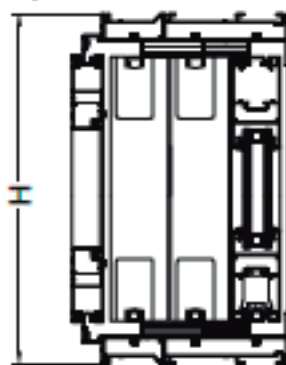
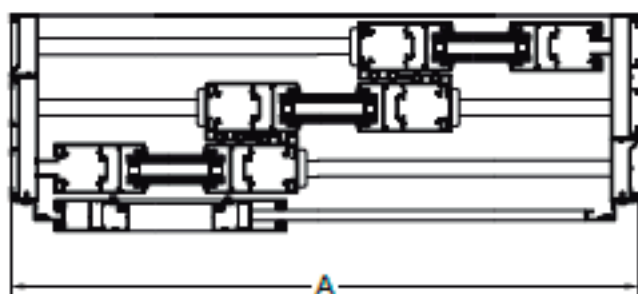



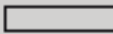

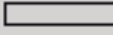

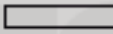

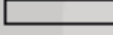

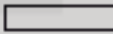

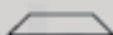

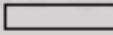

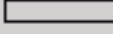

Ancho = Ancho de la hoja - 133

Alto = Alto de la hoja - 133

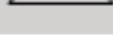
## Listado de perfiles marco 2 guías y guía aplicada

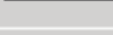

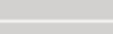







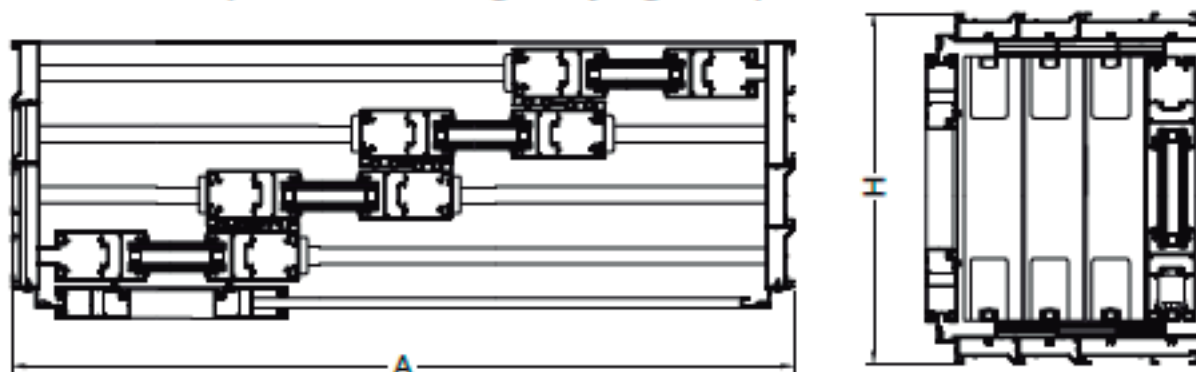



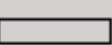



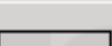





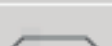

**Vidrio :**  
**Ancho = Ancho de la hoja - 133**  
**Alto = Alto de la hoja - 133**

Código	Perfil	Descripción	Peso (kg/m)	Corte	3 hojas				6 hojas			
					Horizontal		Vertical		Horizontal		Vertical	
					Cant.	Medida	Cant.	Medida	Cant.	Medida	Cant.	Medida
14263		Marco umbral 2 guías	1.857		2	A - 50			2	A - 50		
14262		Marco jamba 2 guías	1.352				2	H			2	H
14283		Marco umbral 1 guía	0.924		2	A - 50			2	A - 50		
14284		Marco jamba 1 guía	0.639				2	H			2	H
13214		Guía	0.100		2 1	A-68 A-50			2 1	A-68 A-50		
14270		Hoja DVH	1.301		6	A/3+35	6	H - 79	12	A/6+45	12	H - 79
14271		Encuentro de hoja	0.543				4	H - 79			8	H - 79
11747		Encuentro 4 hojas	0.288								1	H - 102
99892		Tubo 20x30 mm.	0.405								1	H - 102
14264		Guía mosquitero	0.350		2	A - 6	2	H - 3	2	A - 6	2	H - 3
14062		Mosquitero	0.888		2	A/3+17	2	H - 76	4	A/6+27	4	H - 76
14063		Travesaño mosq.	0.659		1	A/3-119			2	A/6-109		
13934		Premarco	0.900		2	A + 40	2	H + 40	2	A + 40	2	H + 40
14243		Tapajunta	0.254		2	A + 56	2	H + 56	2	A + 56	2	H + 56



## Listado de perfiles marco 2 guías y 2 guías aplicadas

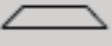

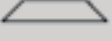
Código	Perfil	Descripción	Peso (kg/m)	Corte	4 hojas en 4 guías			
					Horizontal		Vertical	
					Cant.	Medida	Cant.	Medida
14263		Marco umbral 2 guías	1.857		2	A - 50		
14262		Marco jamba 2 guías	1.352				2	H
14283		Marco umbral 1 guía	0.924		4	A - 50		
14284		Marco jamba 1 guía	0.639				4	H
13214		Guía	0.100		2 2	A-68 A-50		
14270		Hoja DVH	1.301		8	A/4+47	8	H - 79
14271		Encuentro de hoja	0.543				6	H - 79
14264		Guía mosquitero	0.350		2	A - 6	2	H - 3
14062		Mosquitero	0.888		2	A/4+29	2	H - 76
14063		Travesaño mosq.	0.659		1	A/4-107		
13934		Premarco	0.900		2	A + 40	2	H + 40
14243		Tapajunta	0.254		2	A + 56	2	H + 56

### Vidrio :

Ancho = Ancho de la hoja - 133

Alto = Alto de la hoja - 133

## Listado de accesorios marco 2 guías

Código	Descripción	Cantidad				
		2 hojas	3 hojas	4 hojas	6 hojas	
S-009	Grampa de amure (se coloca a 250 mm. de los extremos y luego cada 500 mm.)					
ES001	Escuadra premarco	4				
E-068	Escuadra de alineación tapajunta	4				
E-069	Escuadra para hoja	12	20			
E-078	Escuadra alineación hoja	16	32			
T-088	Distanciador (se coloca a 250 mm. de los extremos y luego cada 500 mm.)					
T-100	Tapón agujero distanciador	1 x T-088				
T-130	Desagüe caja de agua (se coloca a 250 mm. del centro y luego cada 500 mm.)					
T-089	Clapeta (se coloca a 250 mm. de los extremos y luego cada 500 mm.)					
TO001	Tomillo de armado 10 x 1 ½"	8	12	8	12	
T-160	Tapón cruce de hojas marco 2 guías	2	2	4	4	
T-161	Tapón cruce de hojas marco 1 guía		2		4	
T-165	Tope de hojas	2	2	3	3	
T-156	Tapón mecanizado	4	6	8	12	
AA202	Guía superior de hoja	8	12	16	24	
T-162	Tapón caja de agua	2				
H-131	Cierre lateral					
H-133	Cierre lateral bipunto 600 mm. (TANIT)					
	Cierre lateral multipunto (GIESSE) *ver listado de accesorios					
FE004	Felpa 7x6 mm.	Ancho	4			
		Alto	8	12	16	22
RO465	Rueda regulable simple (70 kg. x hoja) (TANIT)					
RO475	Rueda regulable doble (140 kg. x hoja) (TANIT)					
R-46G	Rueda regulable simple (110 kg. x hoja) (GIESSE)	4	6	8	12	
R-47G	Rueda regulable doble (220 kg. x hoja) (GIESSE)					
R-47/40ASR	Rueda regulable simple (200 kg. x hoja) (PABOSE)					
R-47/40ADR	Rueda regulable doble (400 kg. x hoja) (PABOSE)					
B-029 / B-030 / B-031	Burlate para hoja	Ancho	4			
		Alto	8	12	16	24
E-068	Escuadra de alineación guía mosquitero	4				
ES045	Escuadra mosquitero	4	4	8	8	
E-078	Escuadra alineación mosquitero	8	8	16	16	
FE004	Felpa 7x6 mm. para mosquitero	Ancho	2			
		Alto	4	4	8	8
RO105	Rueda mosquitero	2	2	4	4	
TA127	Tope mosquitero	2	2	4	4	
CU001	Cuerda mosquitero	Ancho	1			
		Alto	2	2	4	4

# SISTEMAS DE CARPINTERIA

## DOMO114F

Alta Prestación

MECANIZADOS

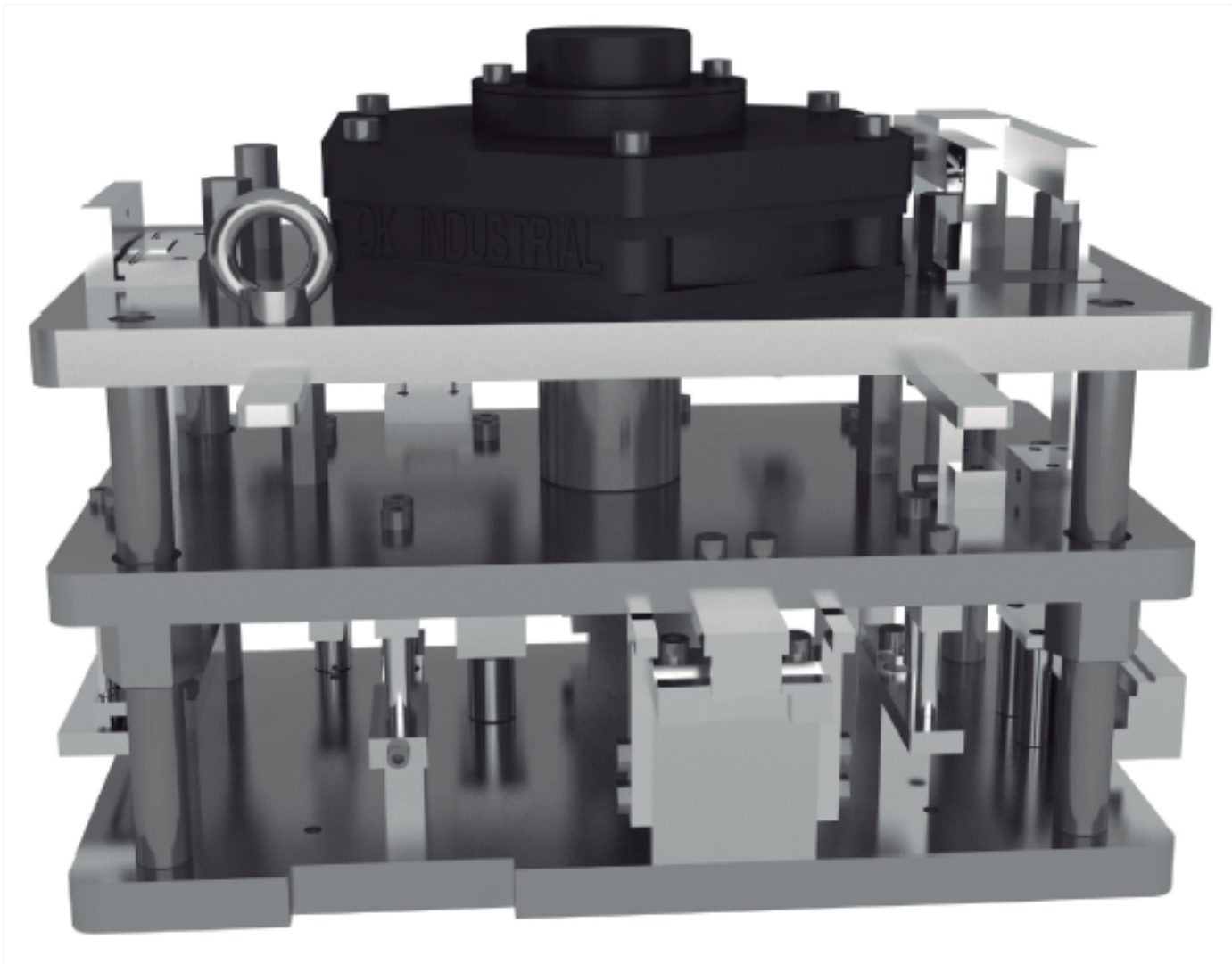

MECANIZADOS  
Punzonadora vista frontal

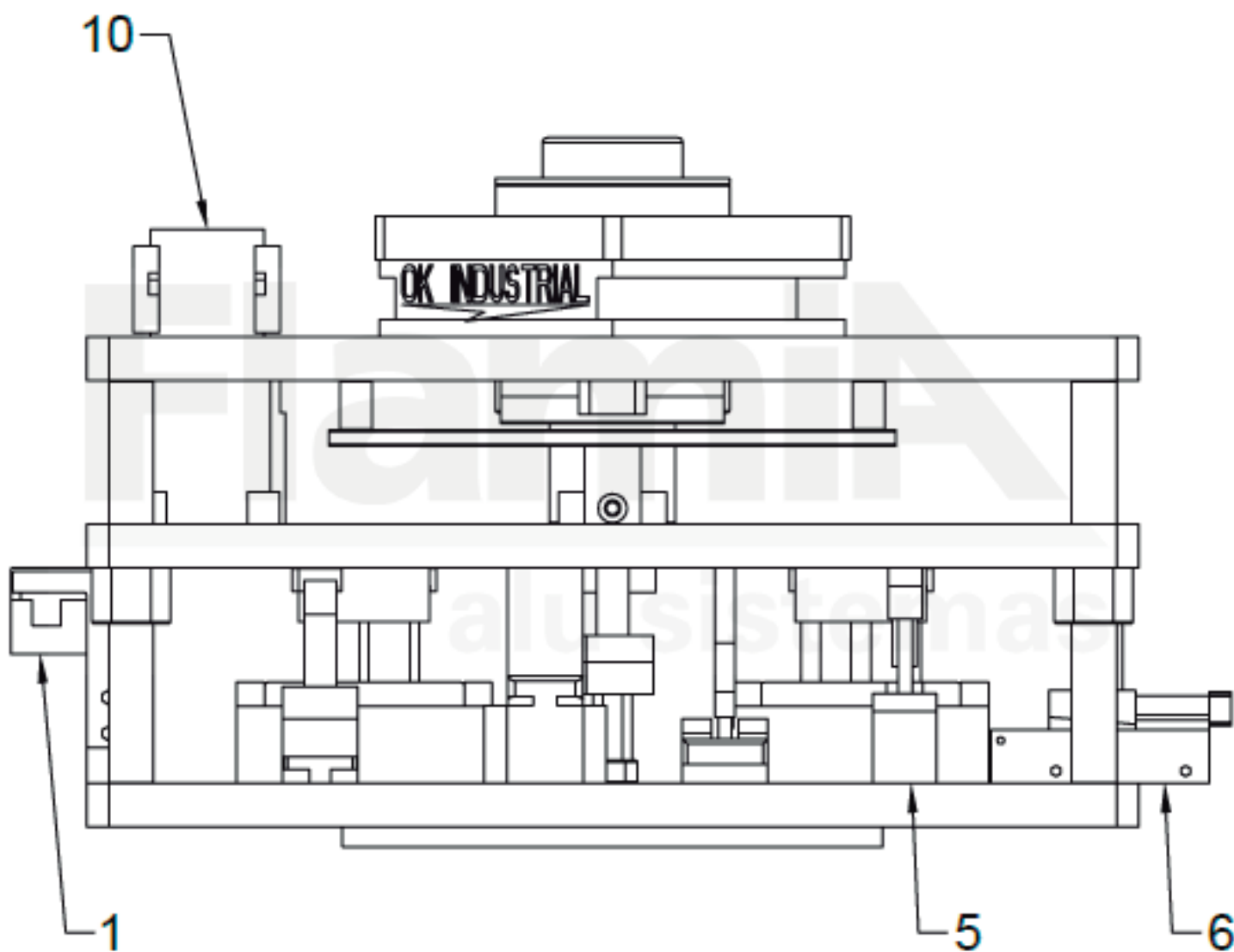

# MECANIZADOS

## Punzonadora vista trasera

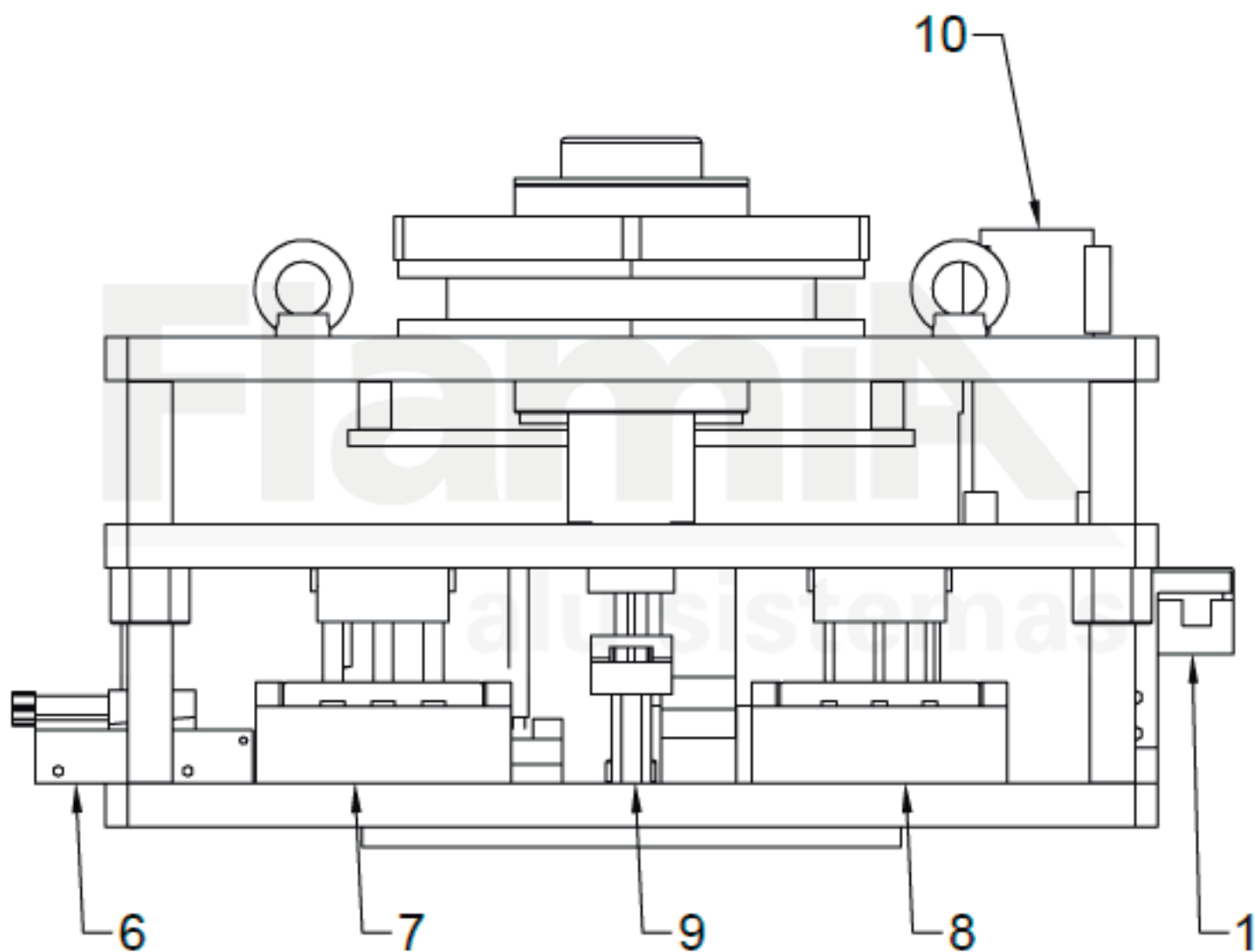

MECANIZADOS  
Punzonadora vista lateral

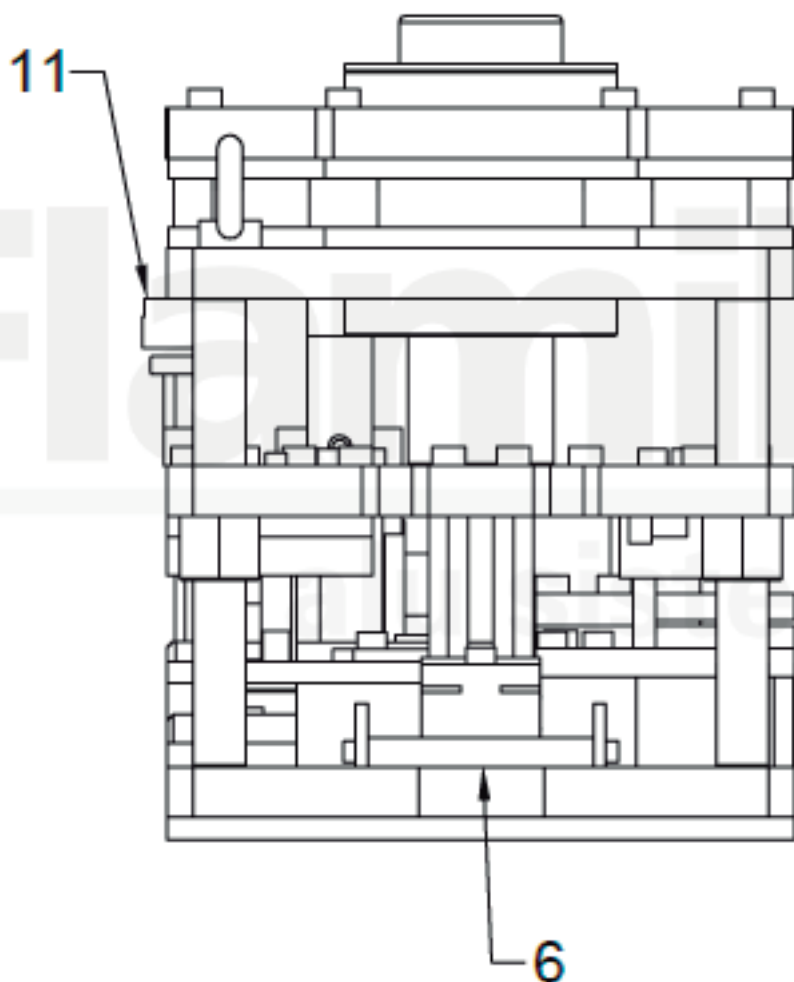

## Modificaciones para realizar en la punzonadora A40

### Punzon Nº10

Hay que colocar un suplemento al conjunto de caja de agua

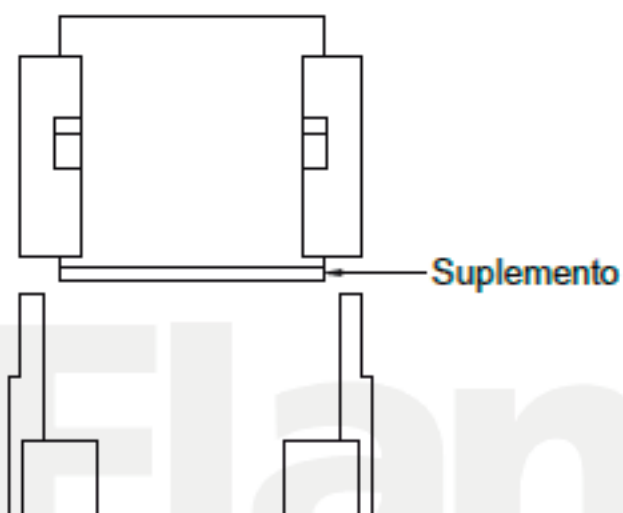

Flamini  
alu sistemas

### Punzon Nº11

Cambiar las piezas A40070 y A40071

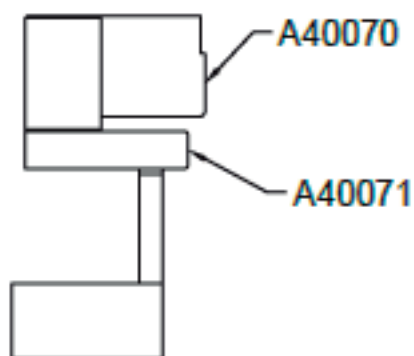

## Mecanizado de perfiles con punzonadora neumática modelo DOMO 114 F

### 1. Perfil N° 14263 y 14283

Mecanizado de desagüe de la guía

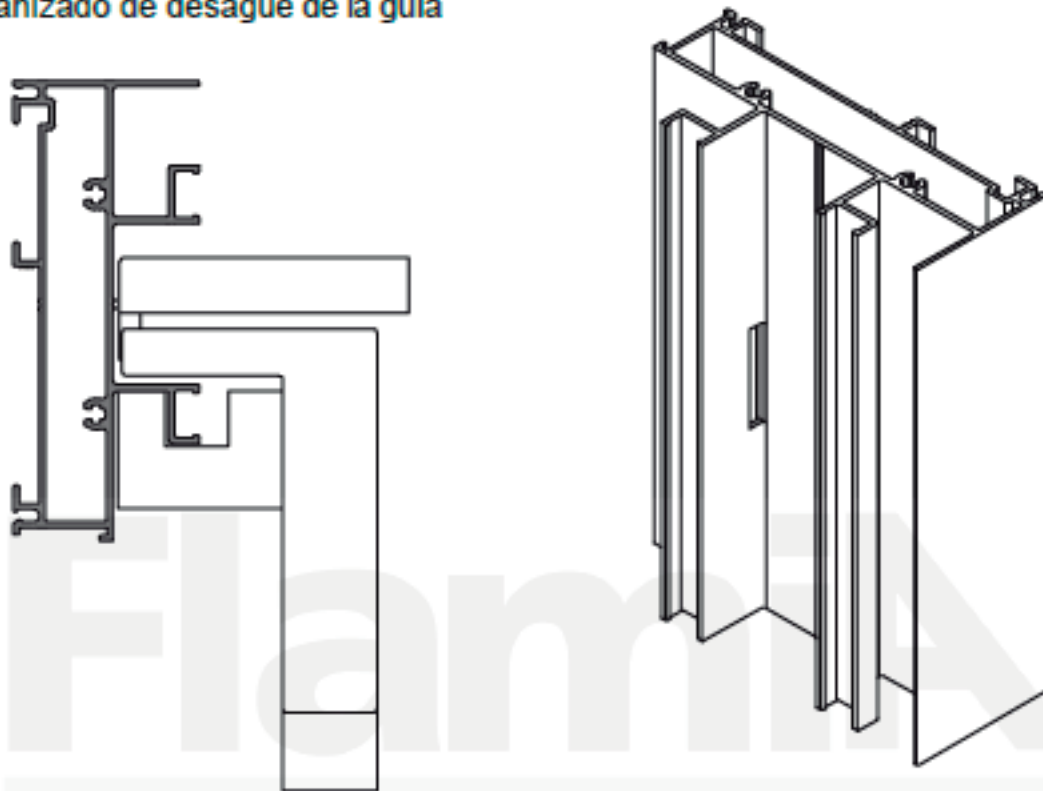

### 5. Perfil N° 14270

Mecanizado para escuadra

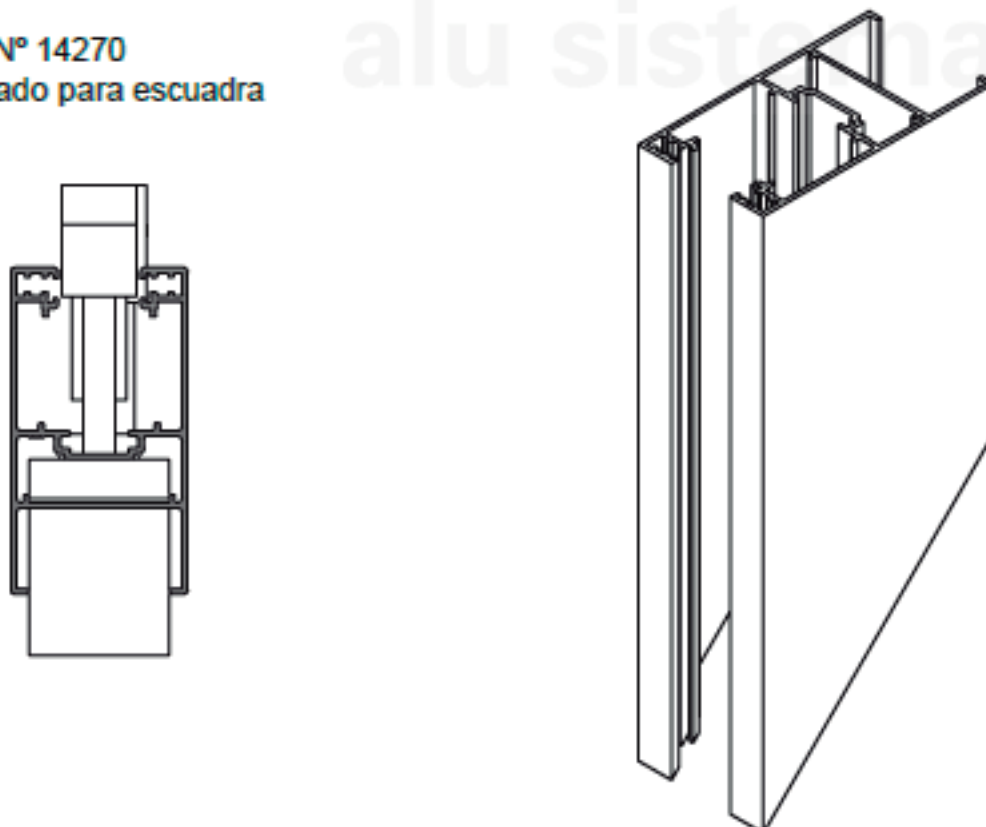



## Mecanizado de perfiles con punzonadora neumática modelo DOMO 114 F

### 6. Perfil N° 14262

Mecanizado de aletas de jamba

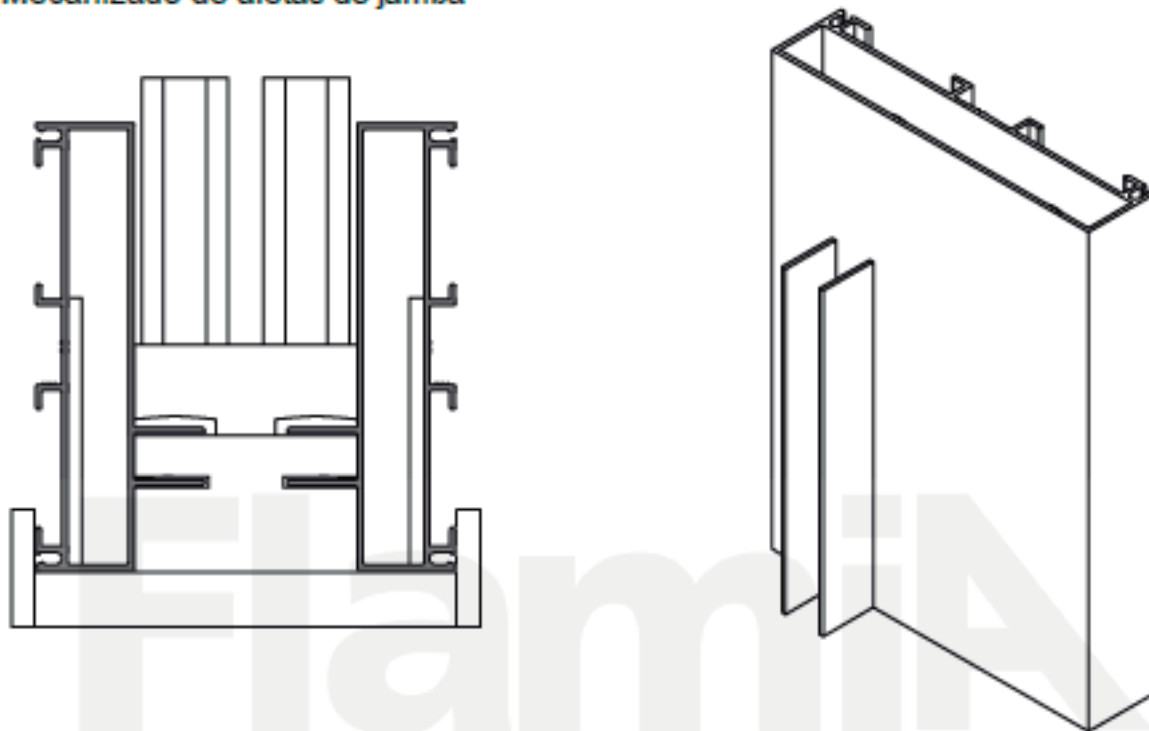

### 7. Perfil N° 14262 (Primero realizar punzonado N° 6)

Mecanizado de jamba para tornillos

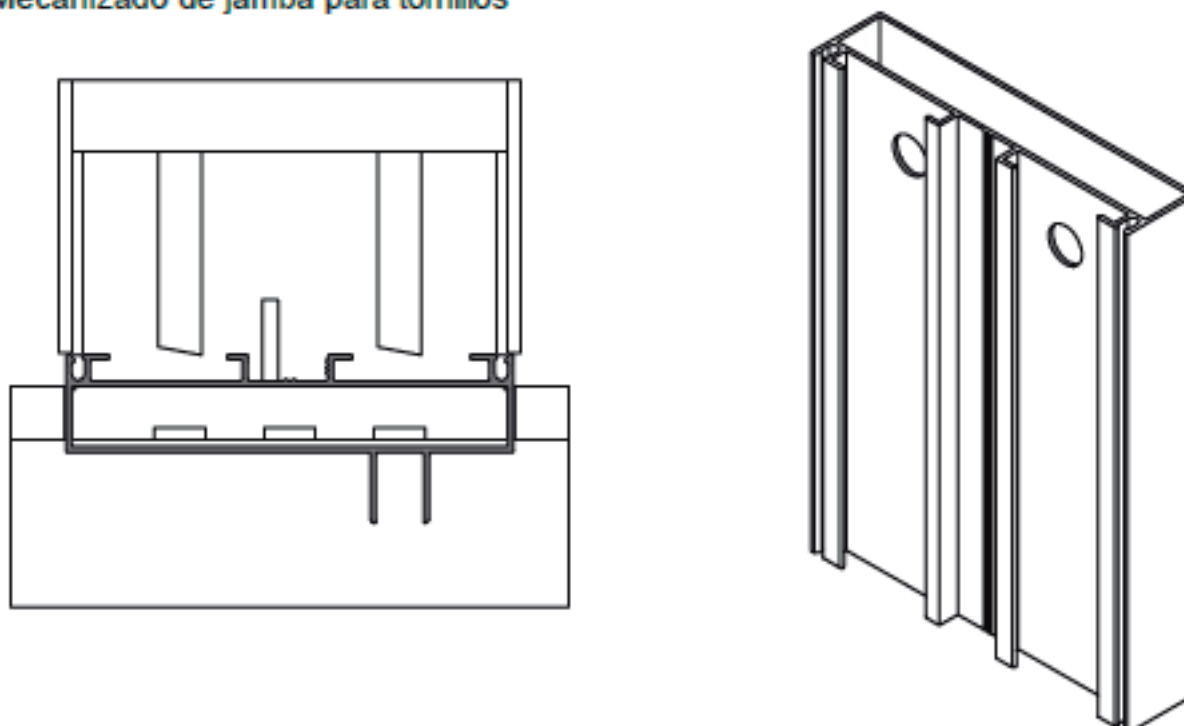

## Mecanizado de perfiles con punzonadora neumática modelo DOMO 114 F

8. Perfil N° 14262 (Primero realizar punzonado N° 6)  
Mecanizado de jamba para tornillos

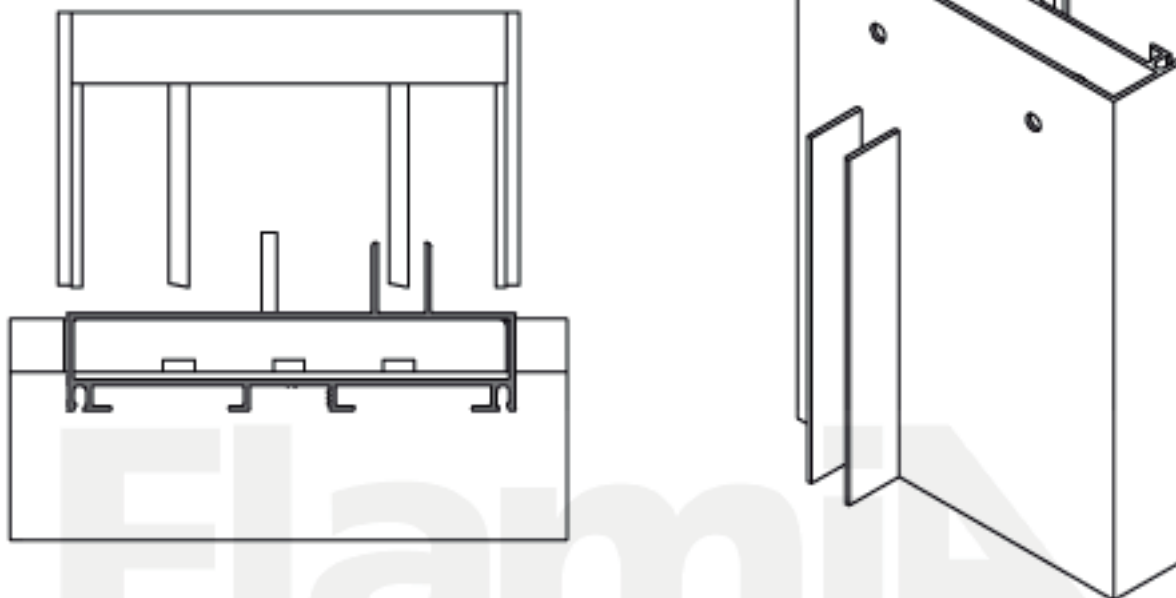

9. Perfil N° 14271  
Mecanizado del encuentro de hoja

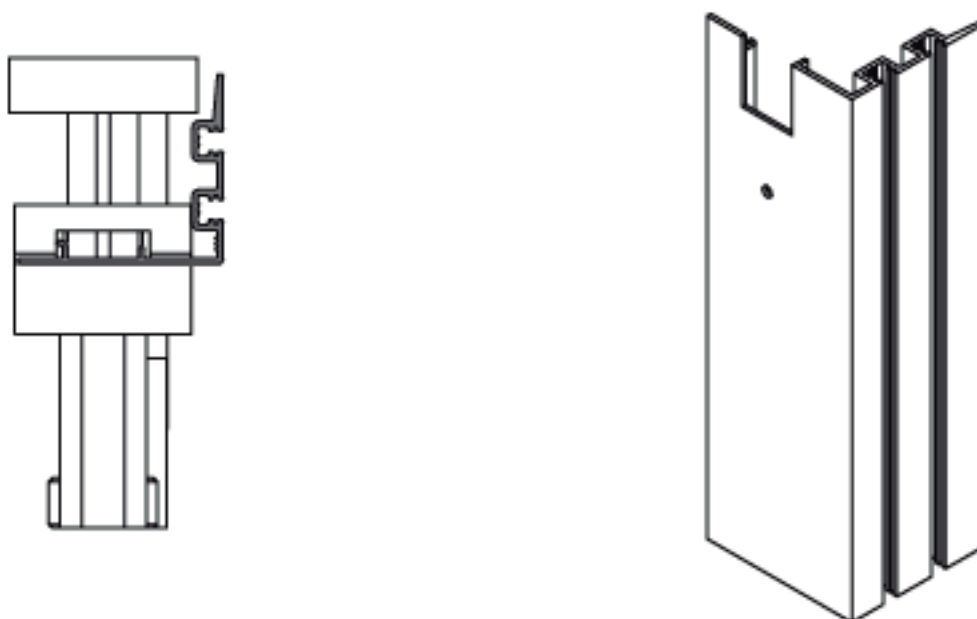

## Mecanizado de perfiles con punzonadora neumática modelo DOMO 114 F

10. Perfil N° 14263  
Mecanizado de caja de agua

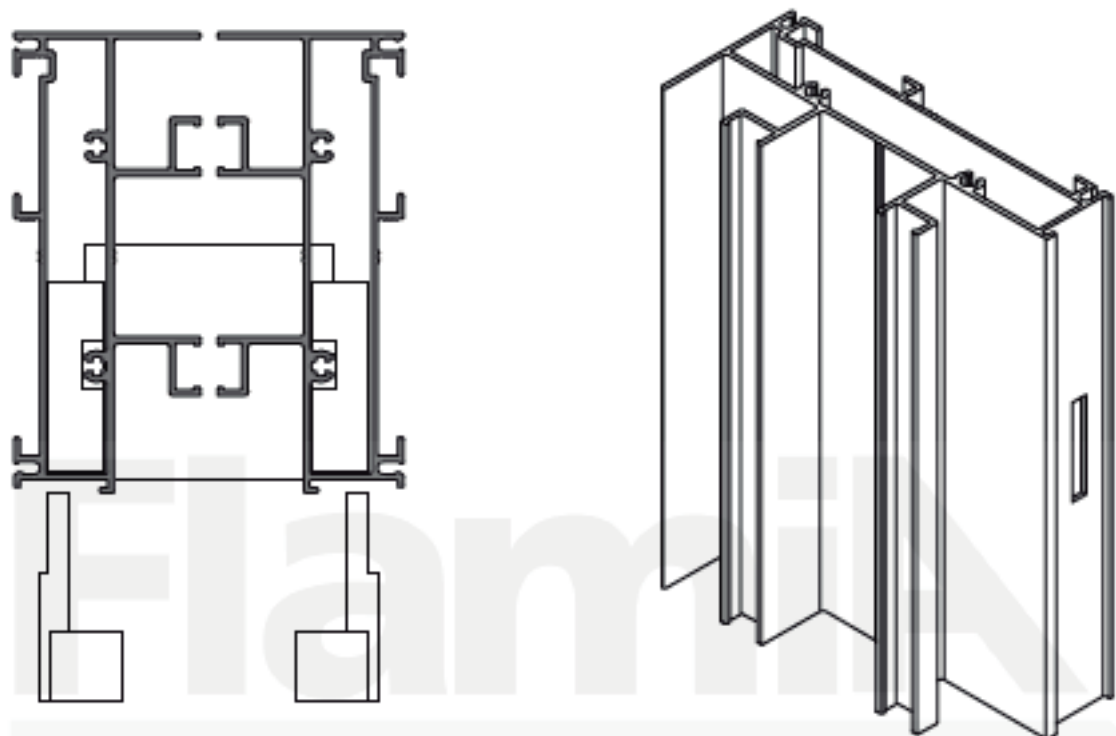

11. Perfil N° 14264  
Mecanizado de desagüe de la guía de mosquitero

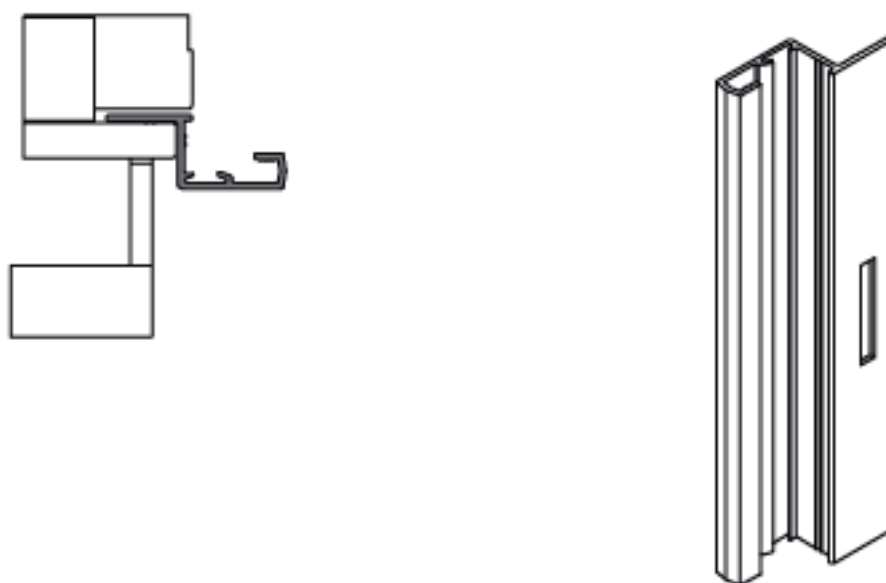

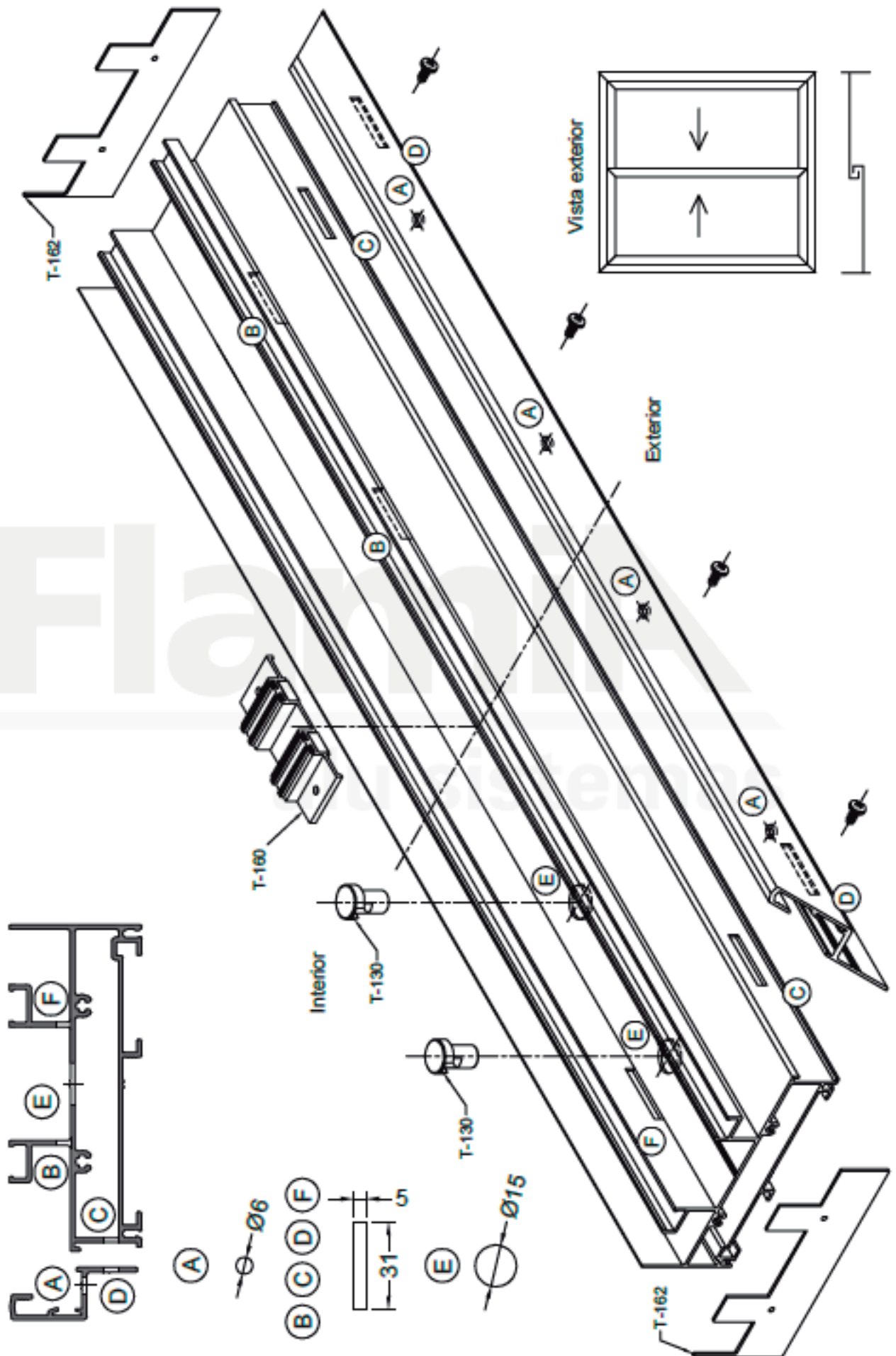

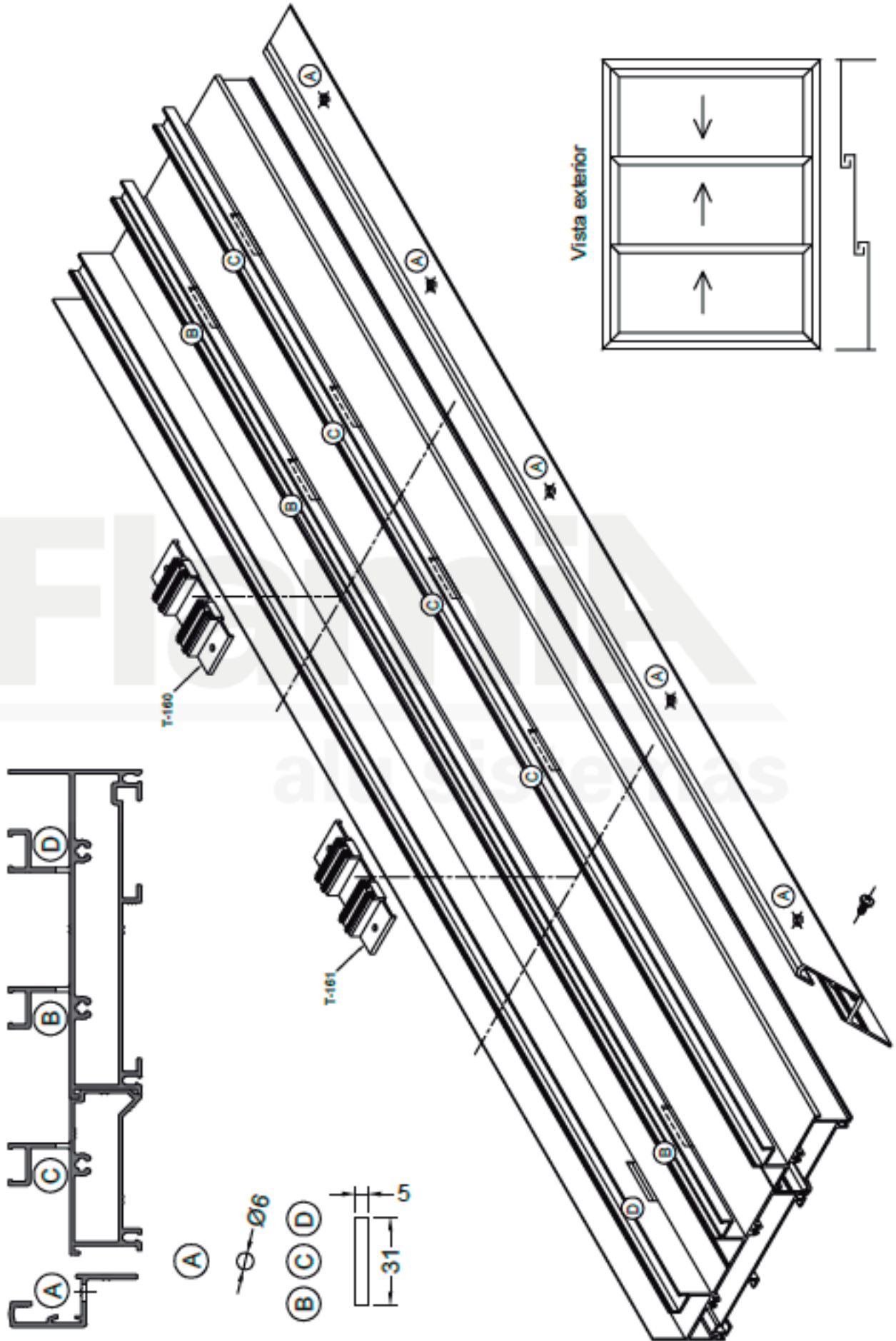

## Mecanizado del tapajuntas 14243 (opción A)

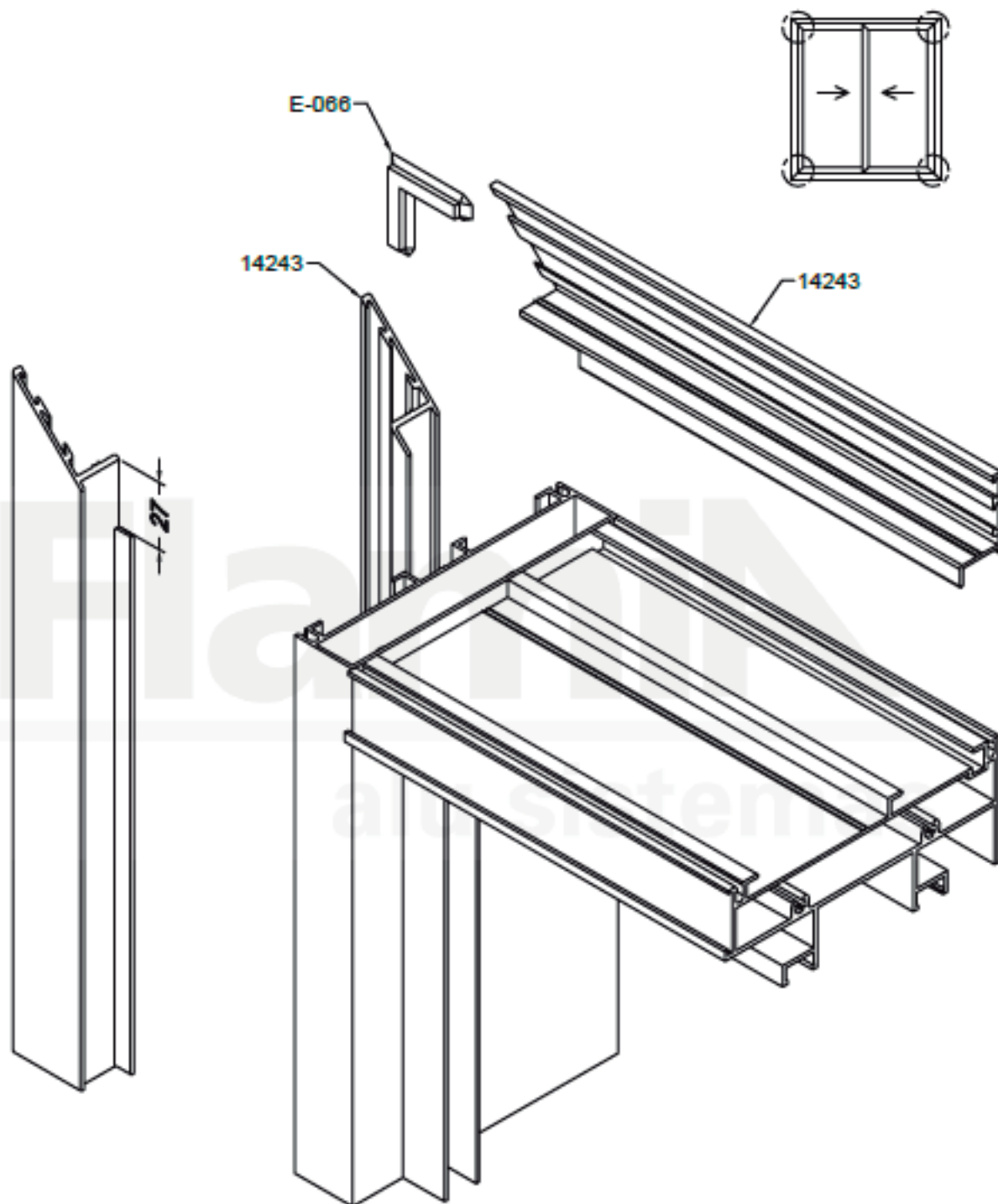

**NOTA:** Este mecanizado se realiza en los perfiles superior e inferior del tapajuntas, el mismo se realiza para evitar mecanizar la jamba de marco.

Mecanizado del tapajuntas 14243 (opción B)

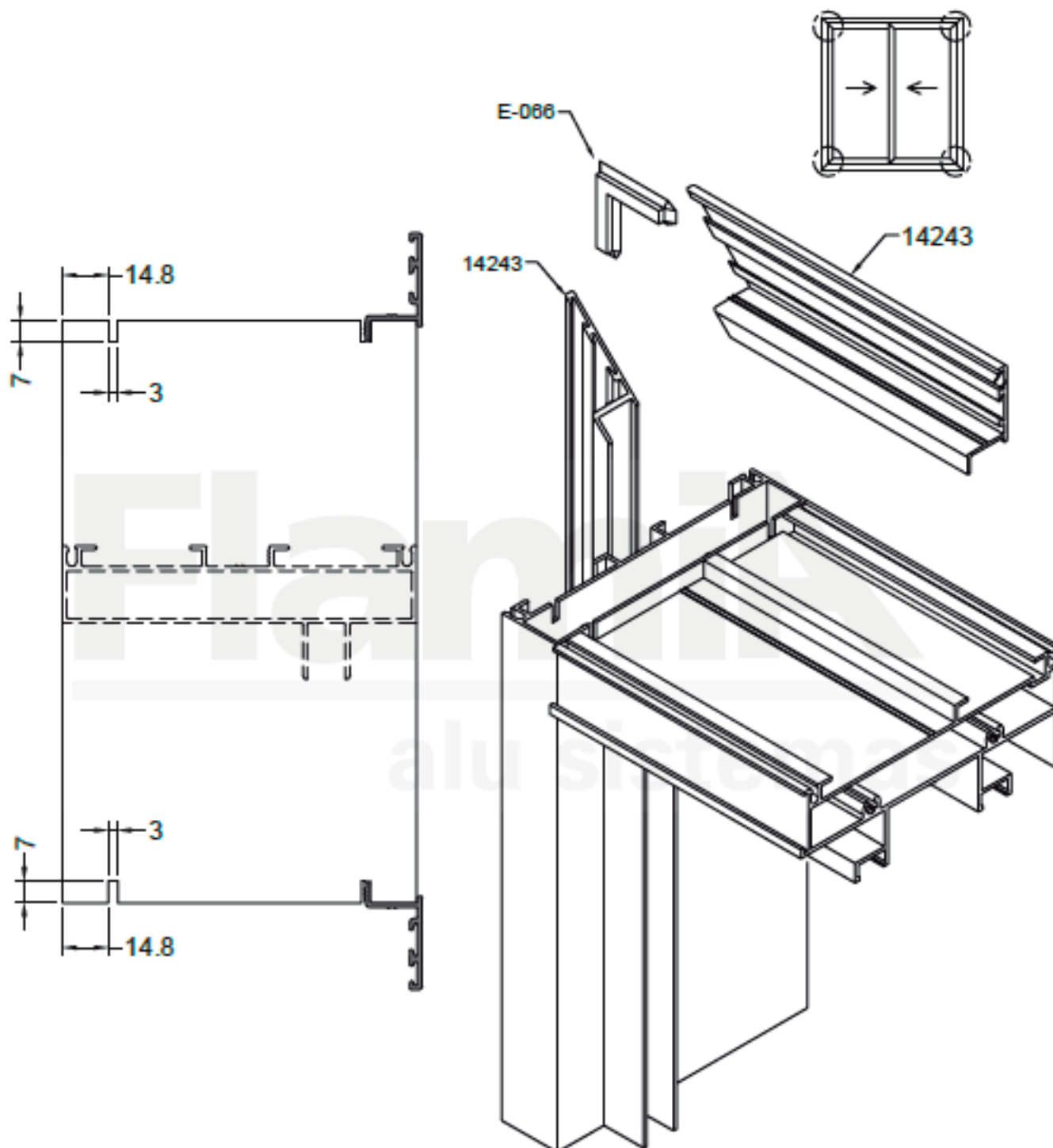

NOTA: Este mecanizado se realiza en la parte superior e inferior de las jambas de marco. Se puede mecanizar solo de un lado, pero tener en cuenta al girar los perfiles de jamba.

Mecanizado de hoja para cierre lateral (H-131)

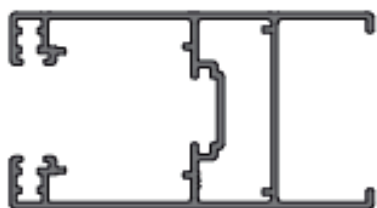

14270

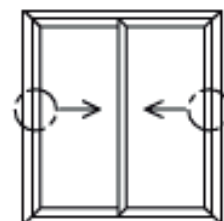

Realizado con  
copiadora

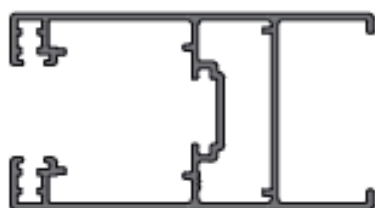



## Colocación del cierre lateral (H-131)

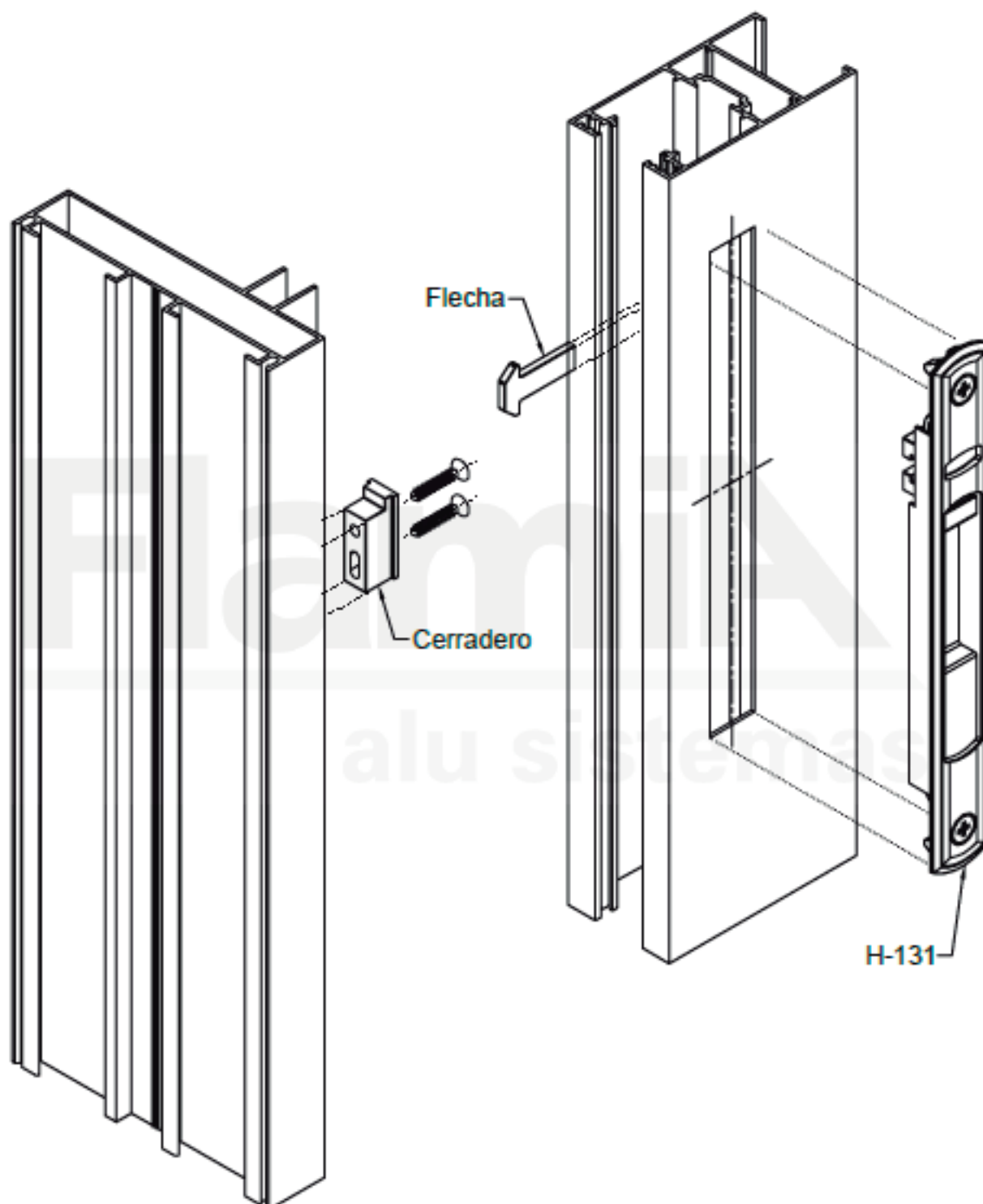

**NOTA:** Primero se debe colocar el cierre lateral en la hoja, luego colocar la flecha en el mismo, y por último colocar el cerradero en el marco usando de guía la misma flecha.

Mecanizado de hoja para cierre lateral bipunto 600 mm. (Tanit H-133)

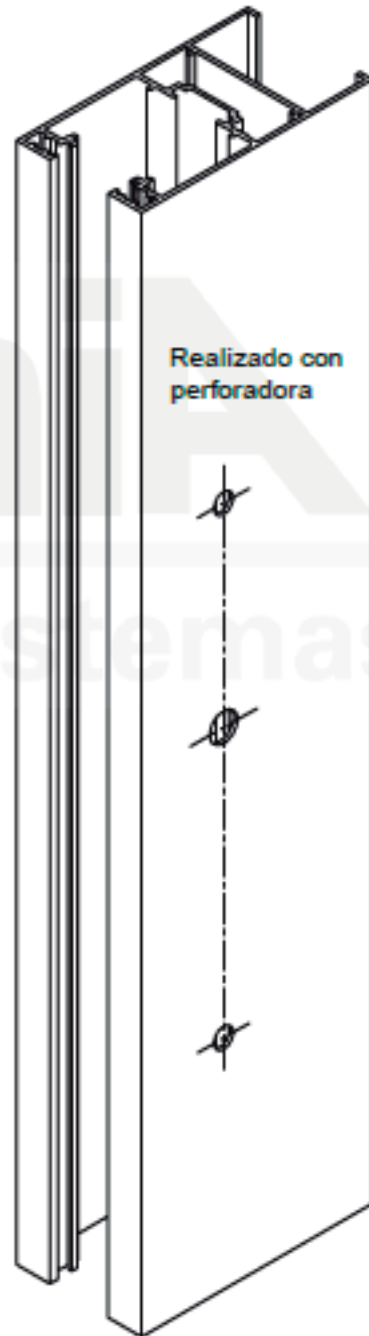
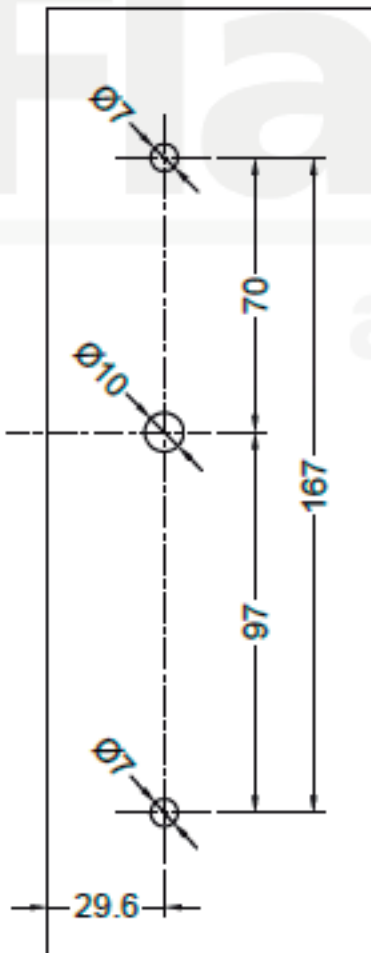
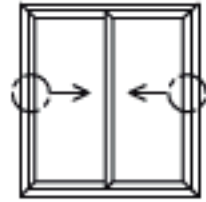
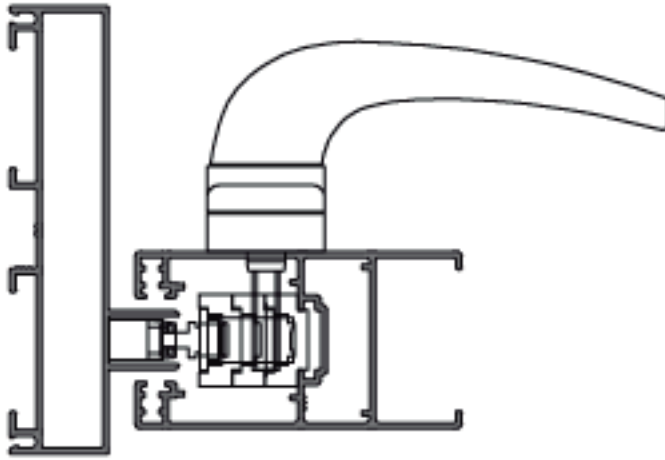

Colocación del cierre bipunto 600 mm. (Tanit H-133)

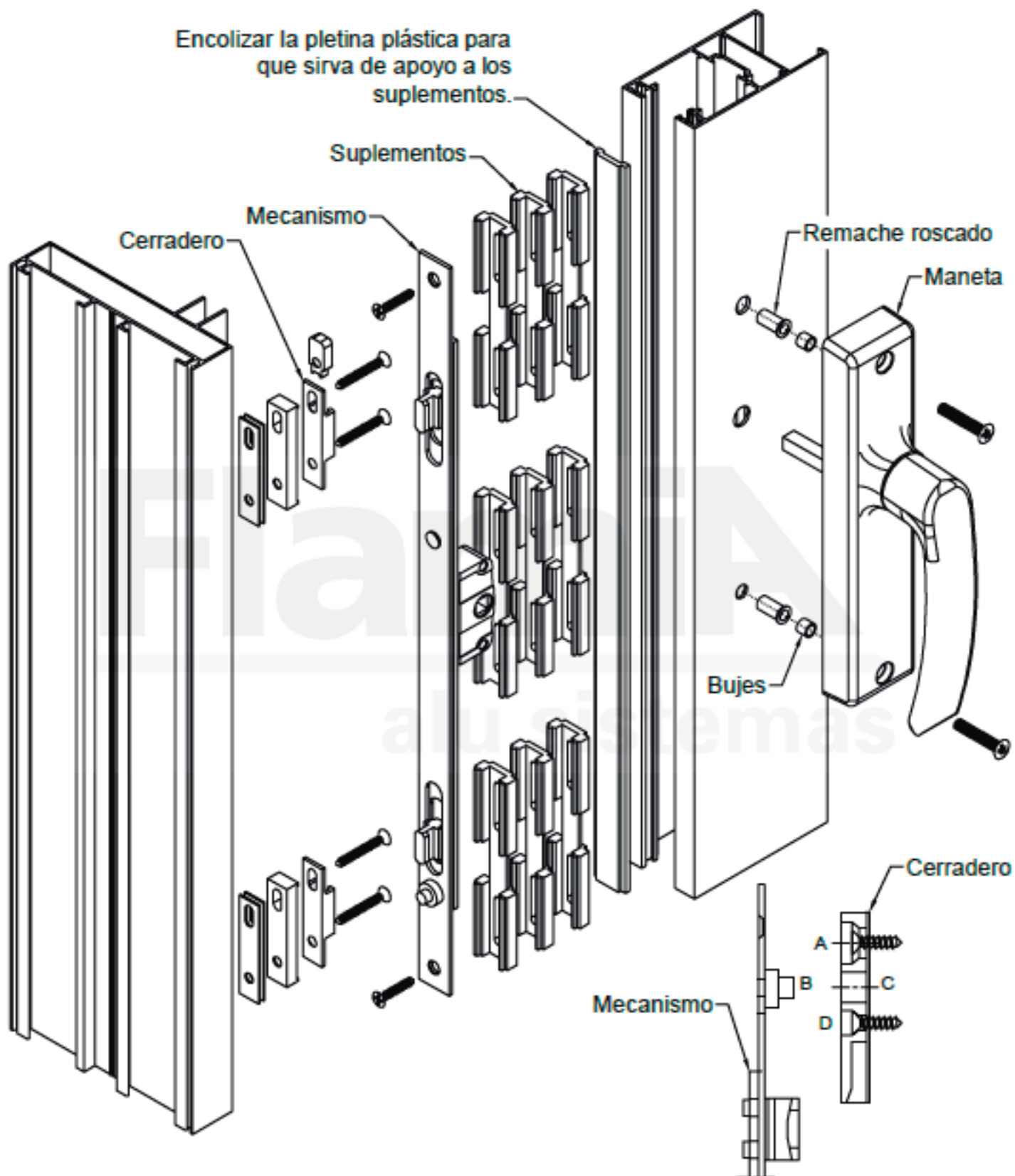

NOTA: Primero se coloca el mecanismo encolizado antes de armar la hoja, los suplementos y se ajusta con los tornillos. Luego se coloca la maneta con los remaches roscados. Por último se atomillan los cerraderos desde el orificio de regulación (A), luego se alinea el tope (B) con el orificio (C) y se termina de fijar con un tornillo en el orificio (D).

## Colocación del cierre (Giese)

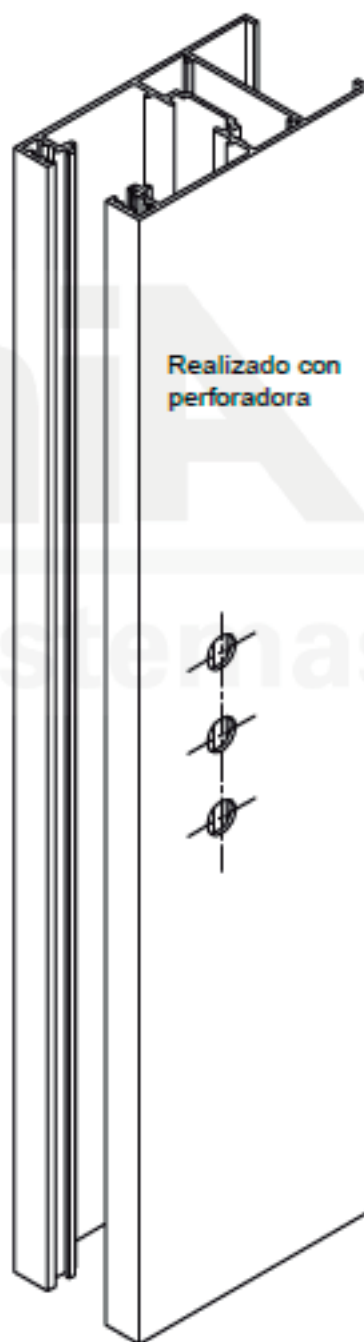
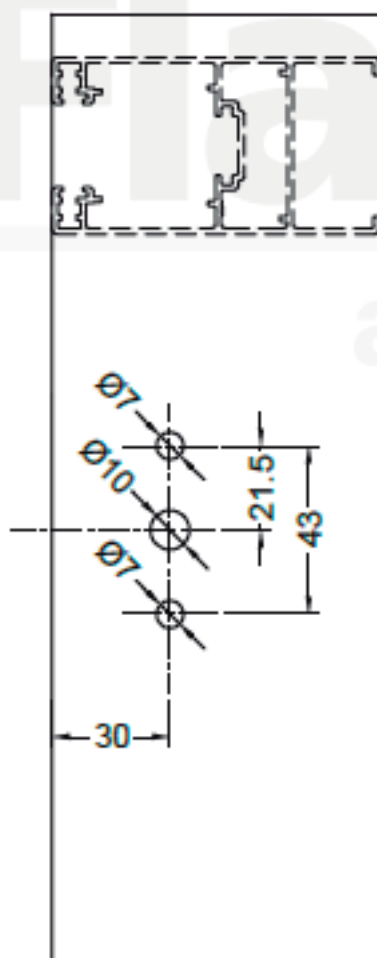
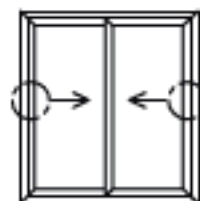
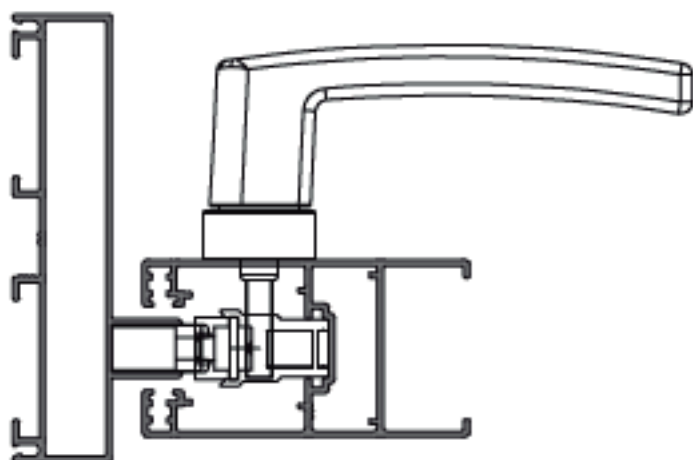

## Colocación del cierre (Giese)

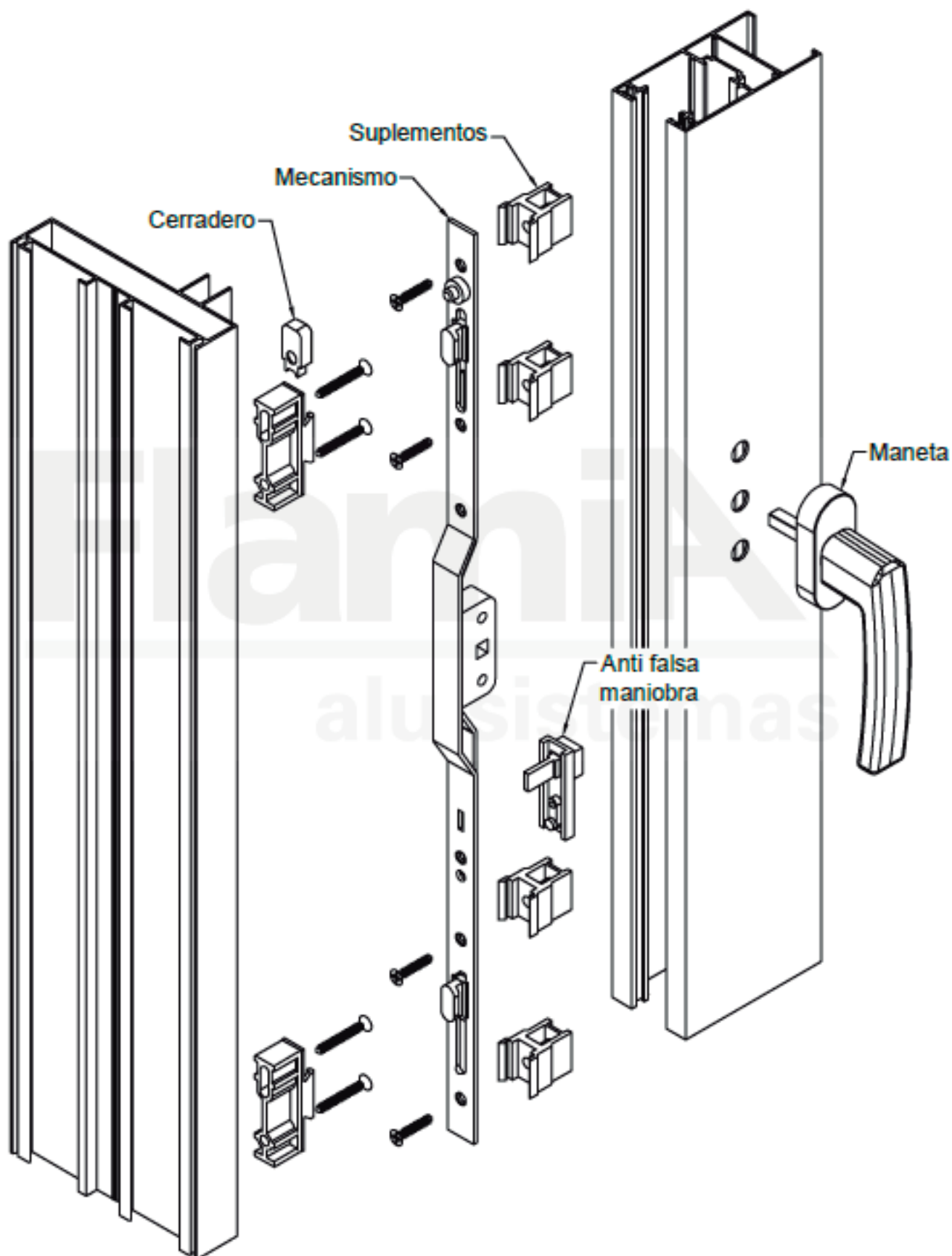

## Ventana corrediza (Marco 2 guías) Ensamble del marco

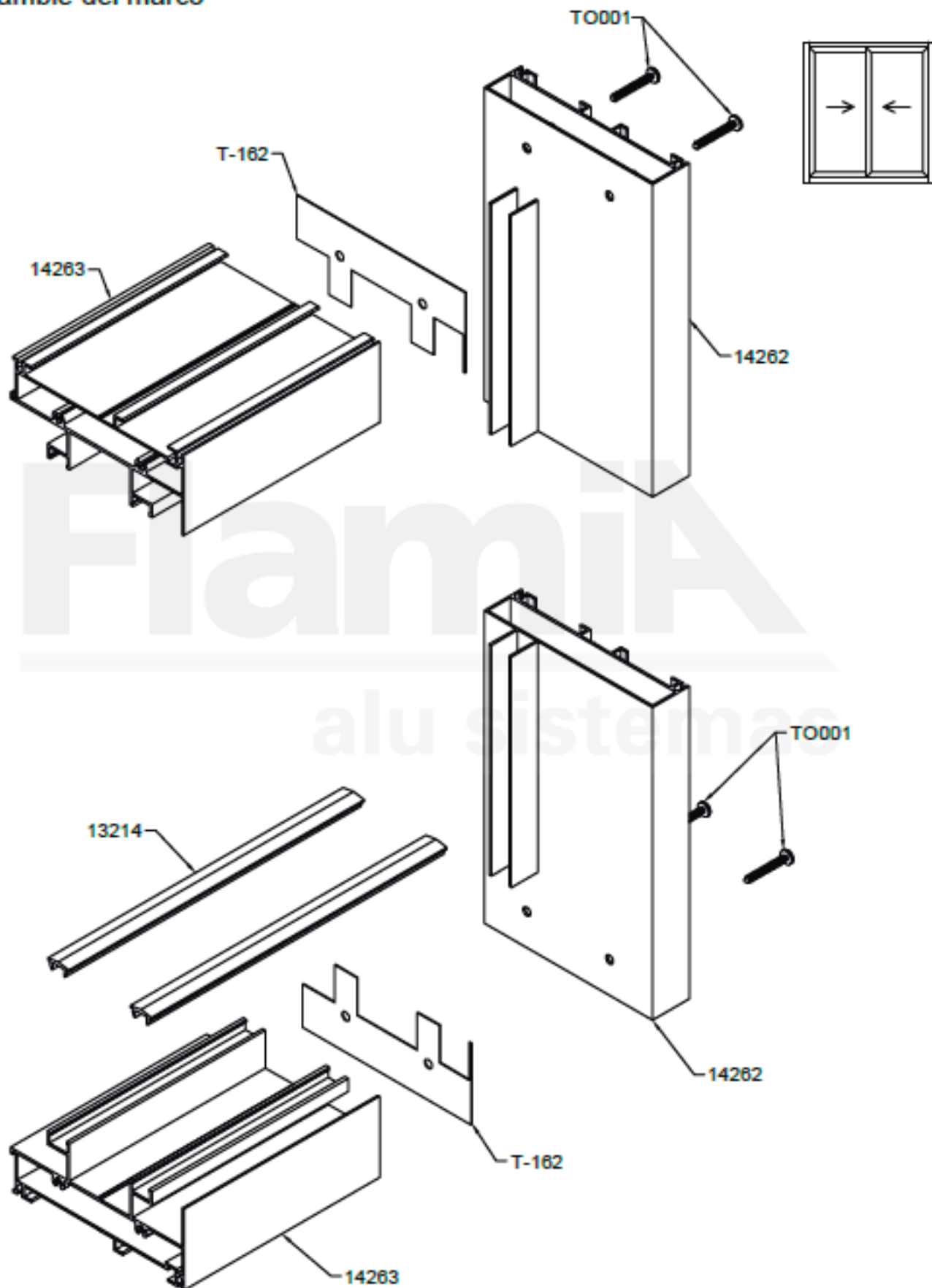

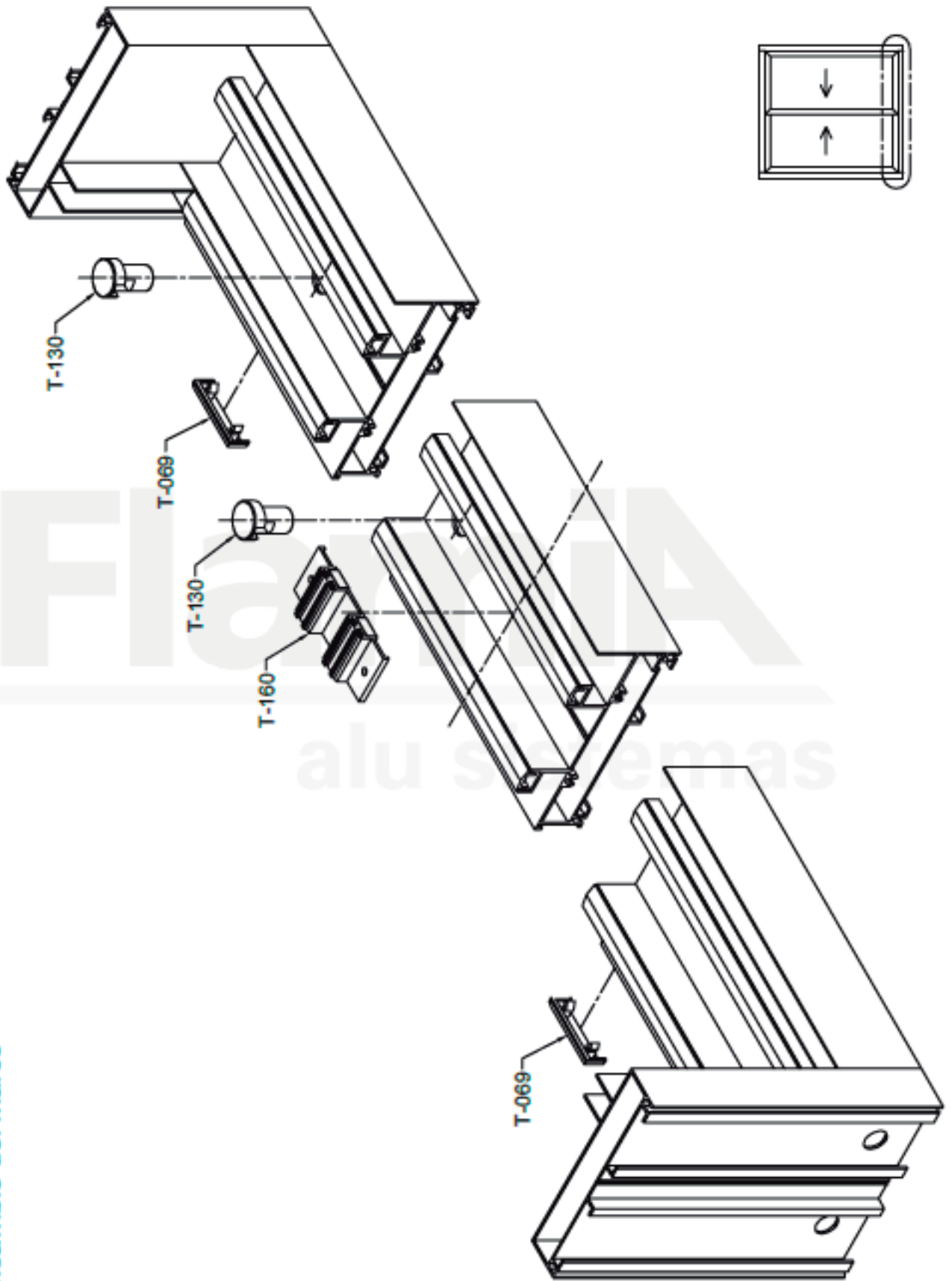

Ventana corrediza (Marco 2 guías)  
Ensamble del marco

Ventana corrediza (Marco 2 guías)  
Ensamble de la guía de mosquitero

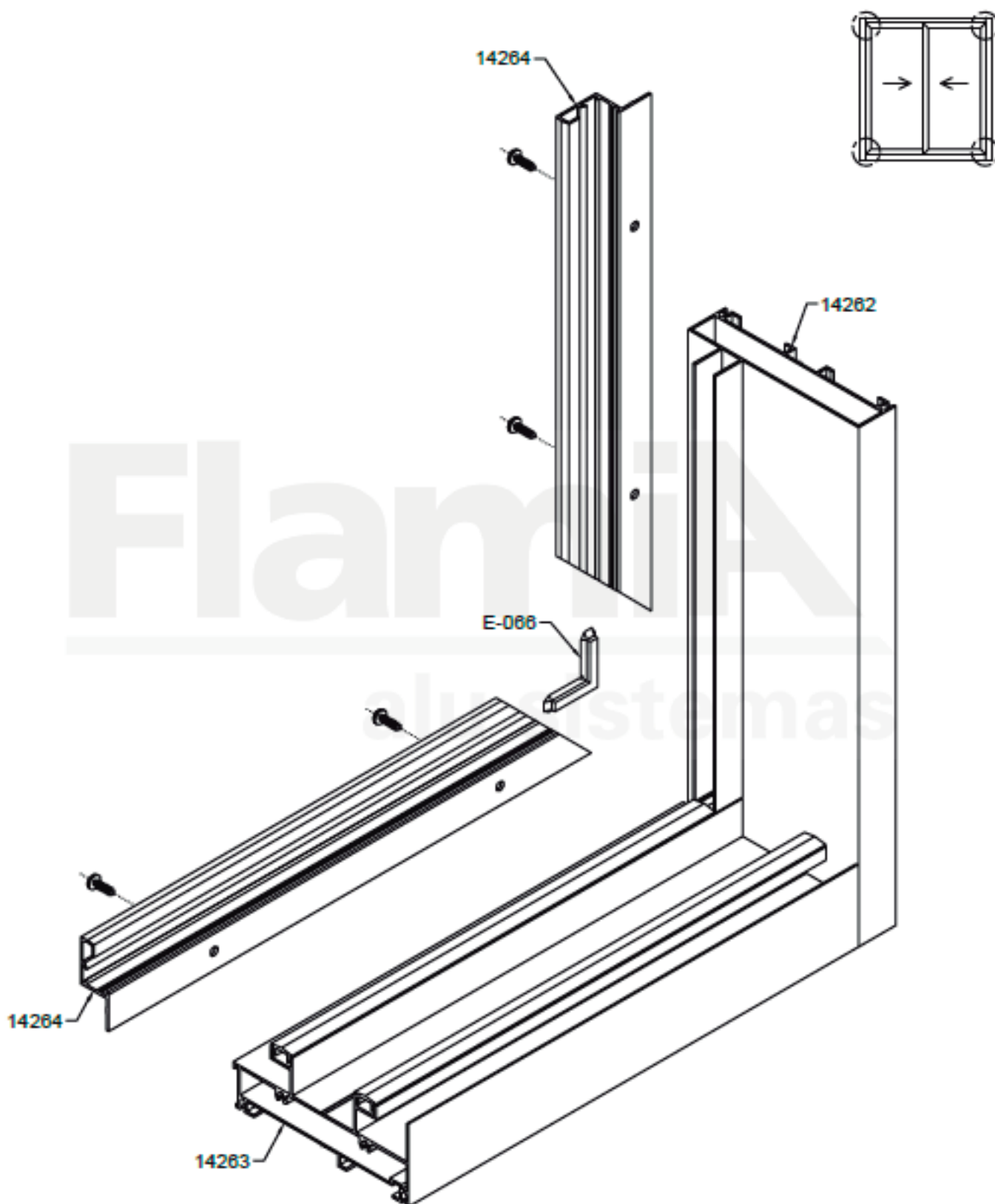



## Ventana corrediza (Marco 2 guías) Ensamble de la hoja

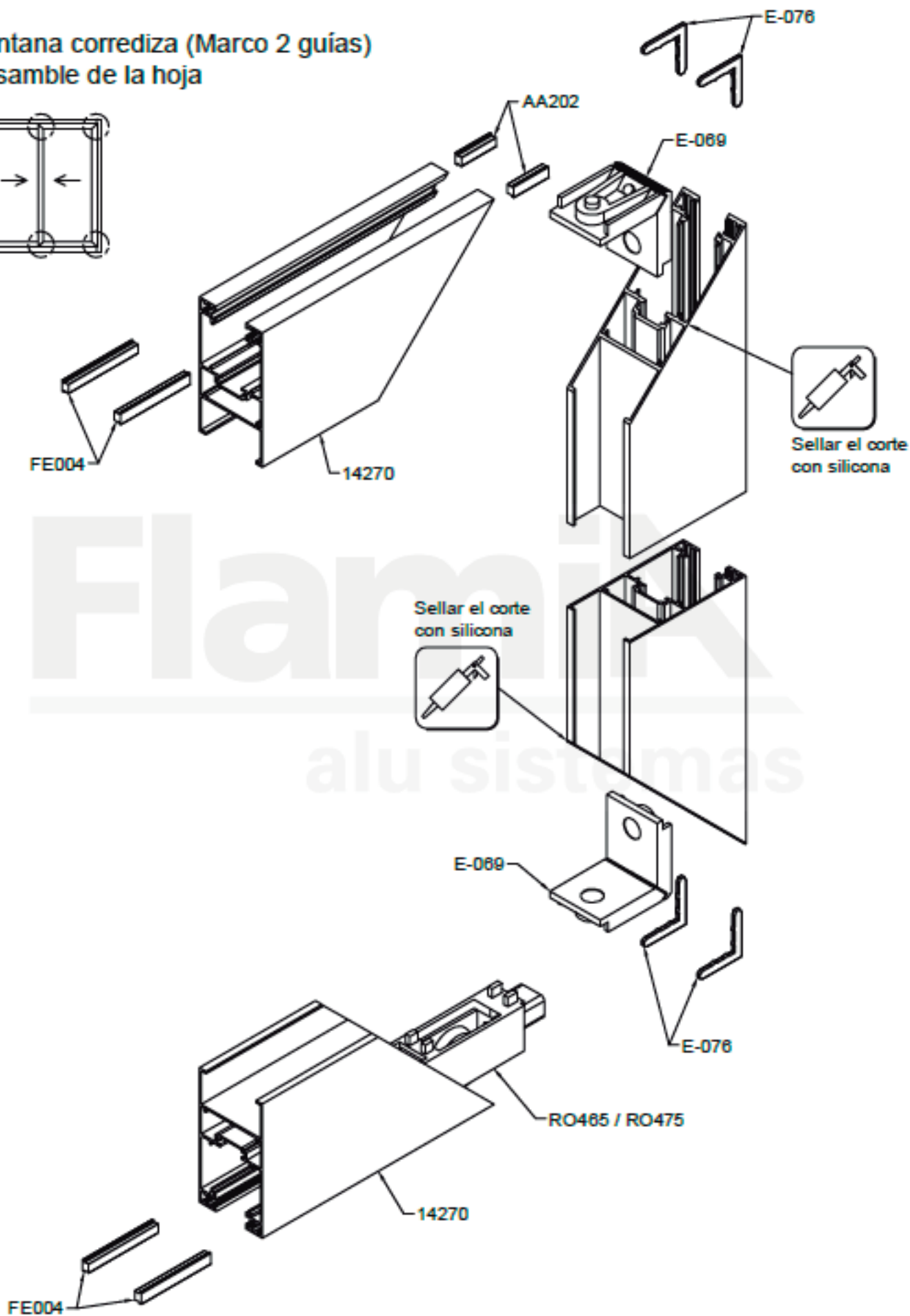
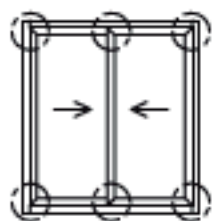

## Ventana corrediza (Marco 2 guías) Ensamble de la hoja

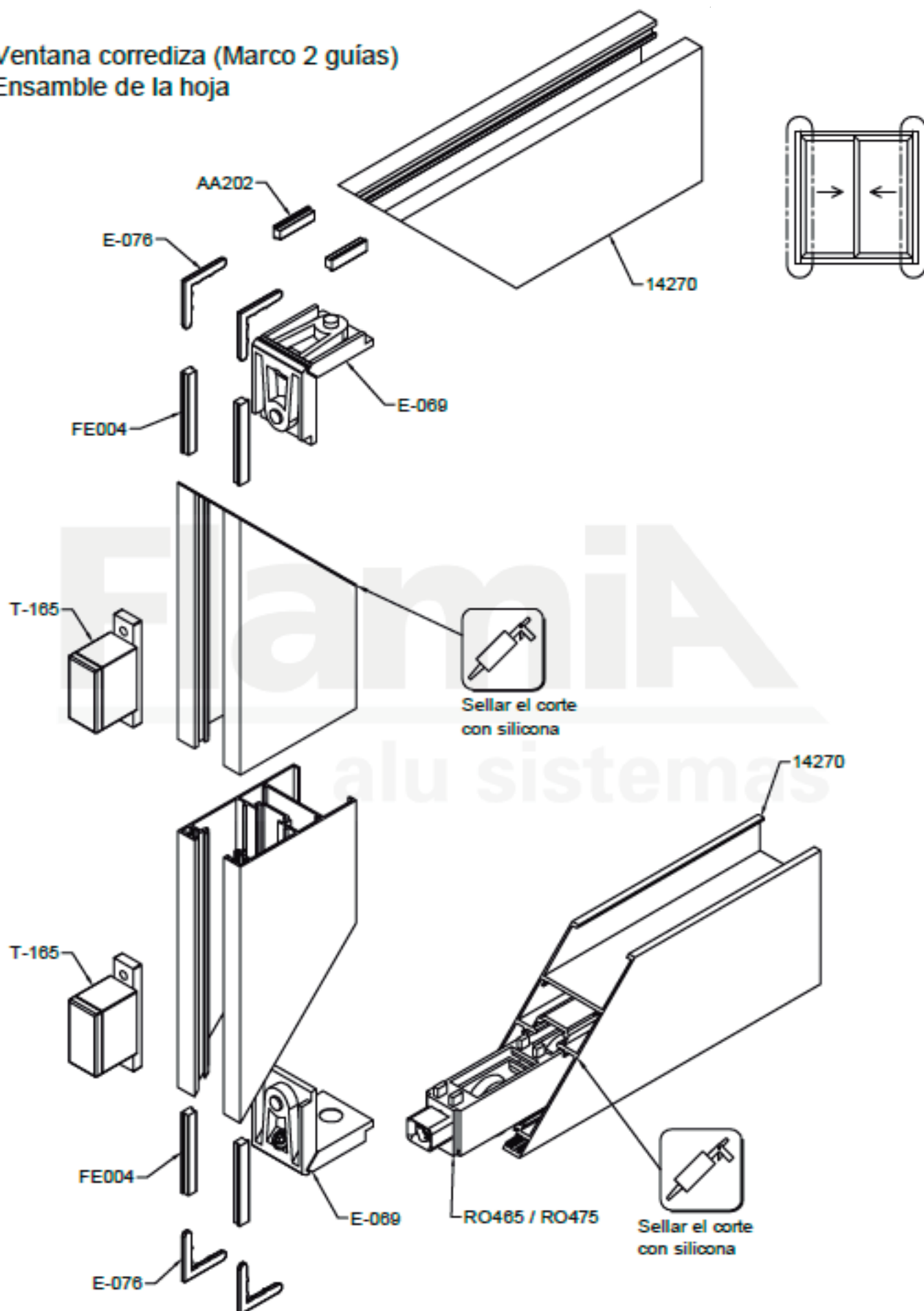

## Ventana corrediza (Marco 2 guías) Ensamble de la hoja

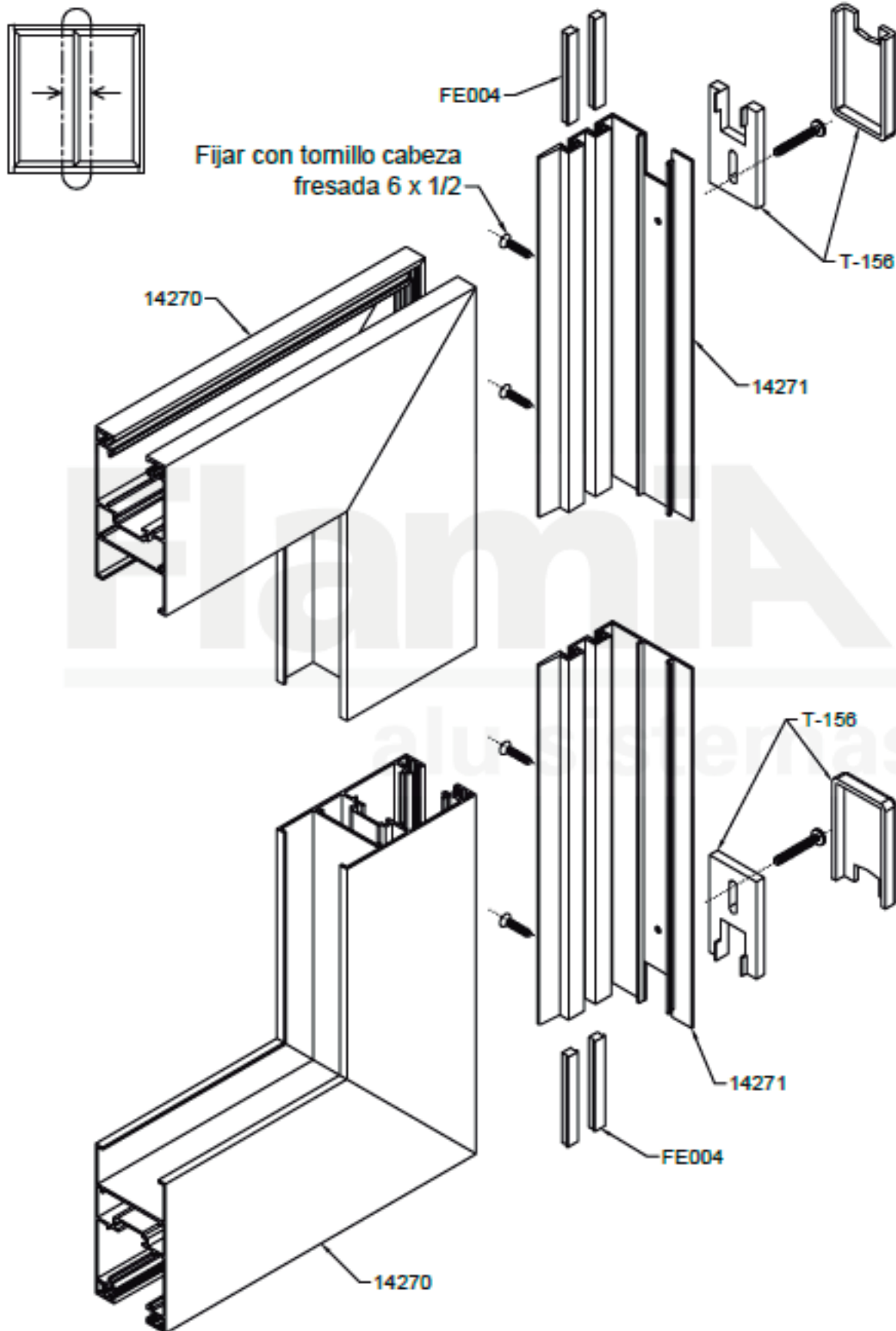

## Ventana corrediza (Marco 2 guías) Ensamble del cruce de 4 hojas

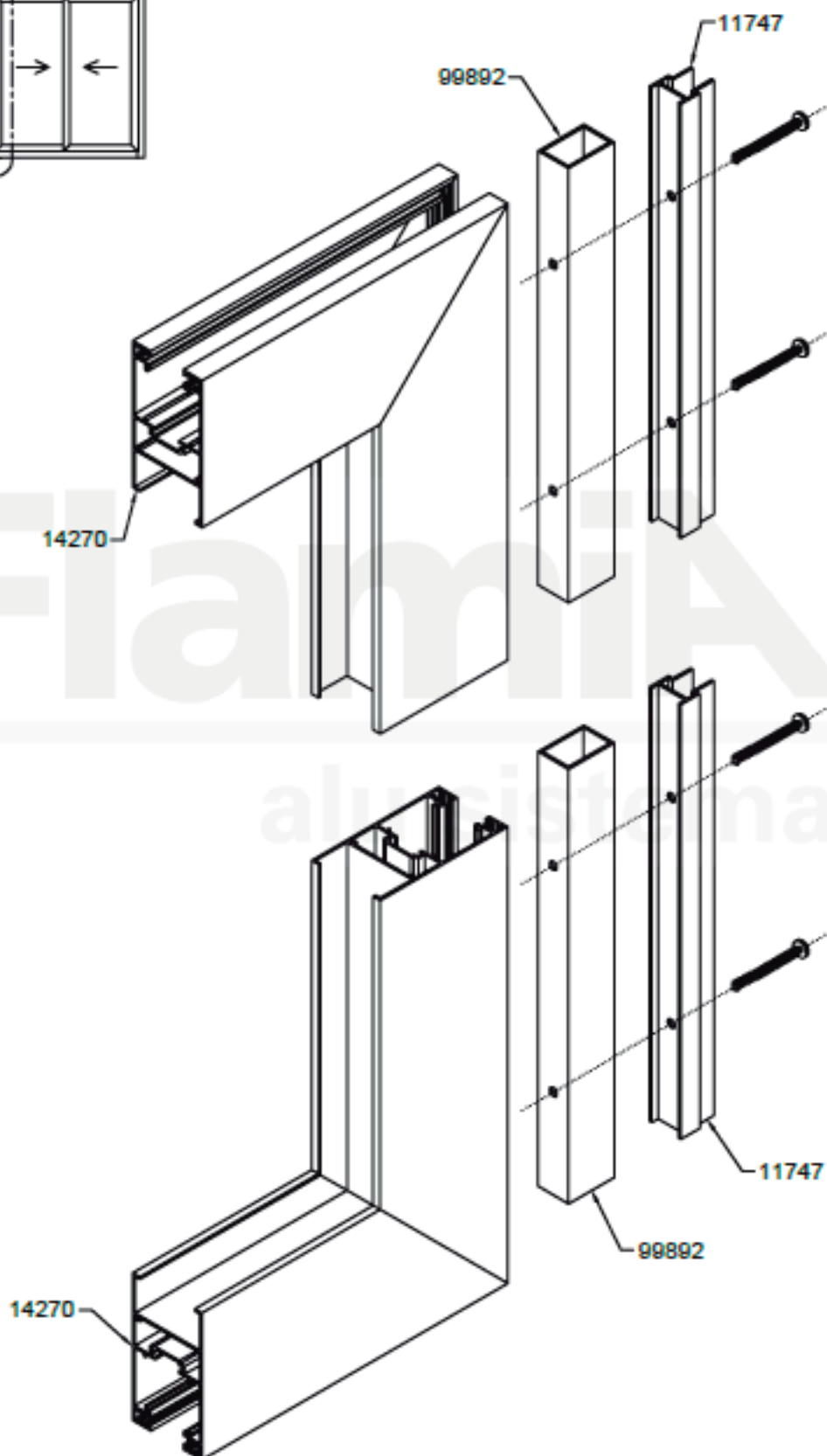
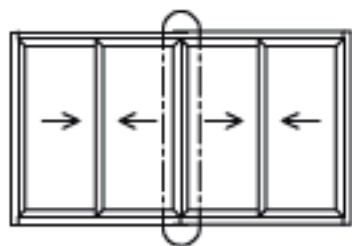

# SISTEMAS DE CARPINTERIA

## DOMO114F

Alta Prestación

ACRISTALAMIENTO



ACRISTALAMIENTO

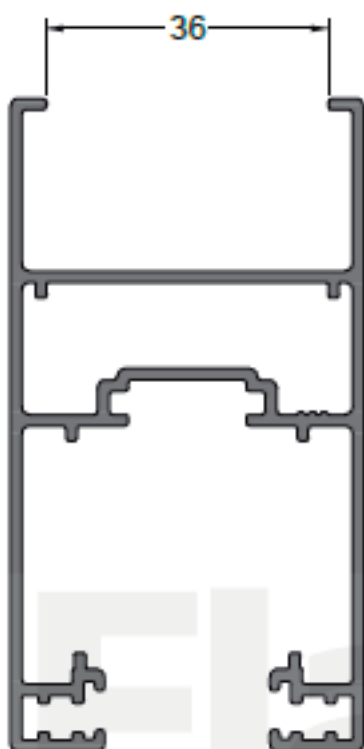

14270

RECOMENDACIONES PARA EL TAQUEADO DE VIDRIOS

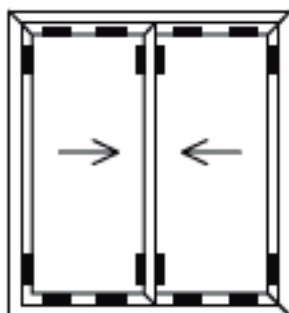

Corrediza 2 hojas

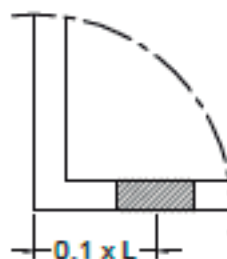

Nota: La distancia entre el centro de los calzos y el borde del vidrio debe ser aproximadamente  $L / 10$  (L = Ancho del vidrio)

# SISTEMAS DE CARPINTERIA

## DOMO114F

Alta Prestación

DIMENSIONES

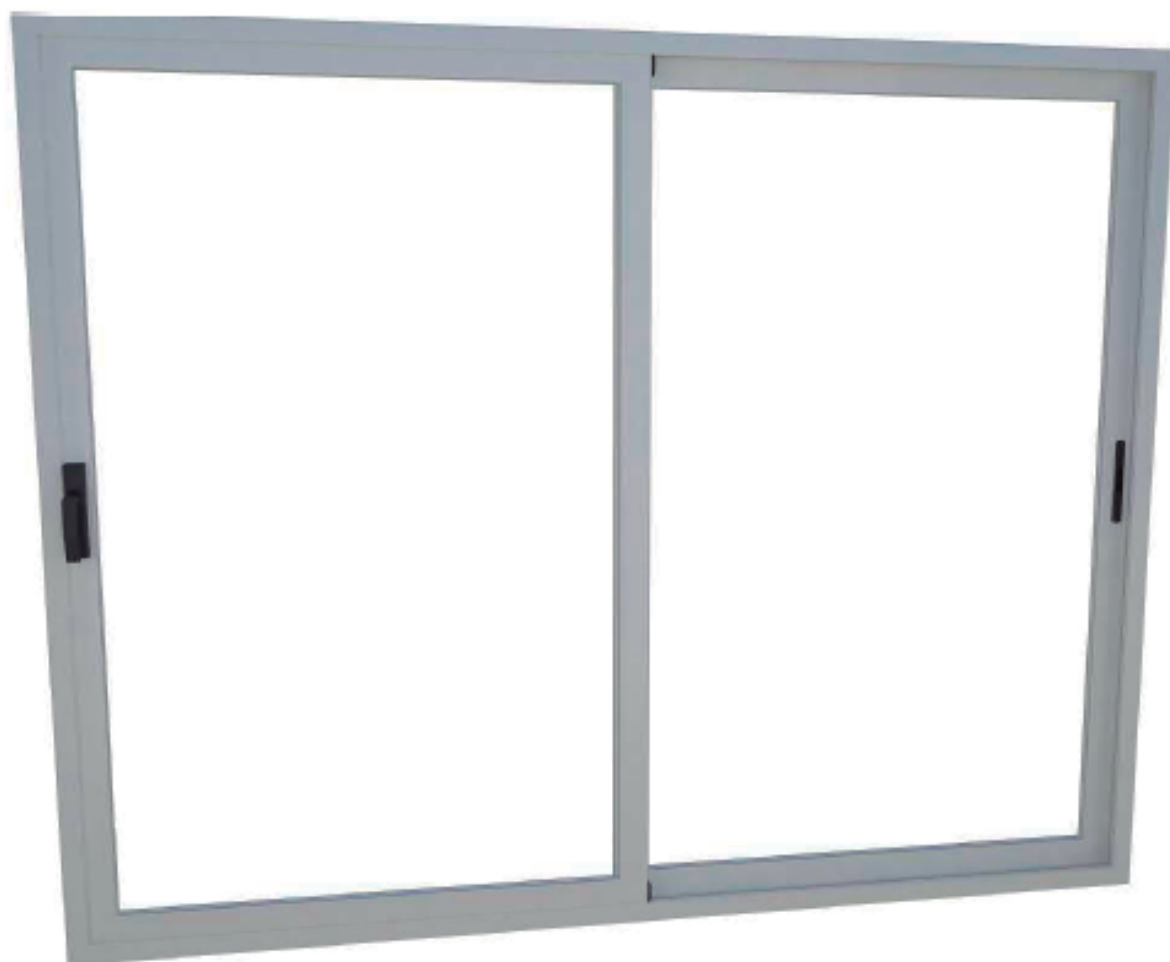

## Dimensiones máximas para ventana corrediza

A) 14270 + 14271

$$J_{xx} = 49.7 \text{ cm}^4$$

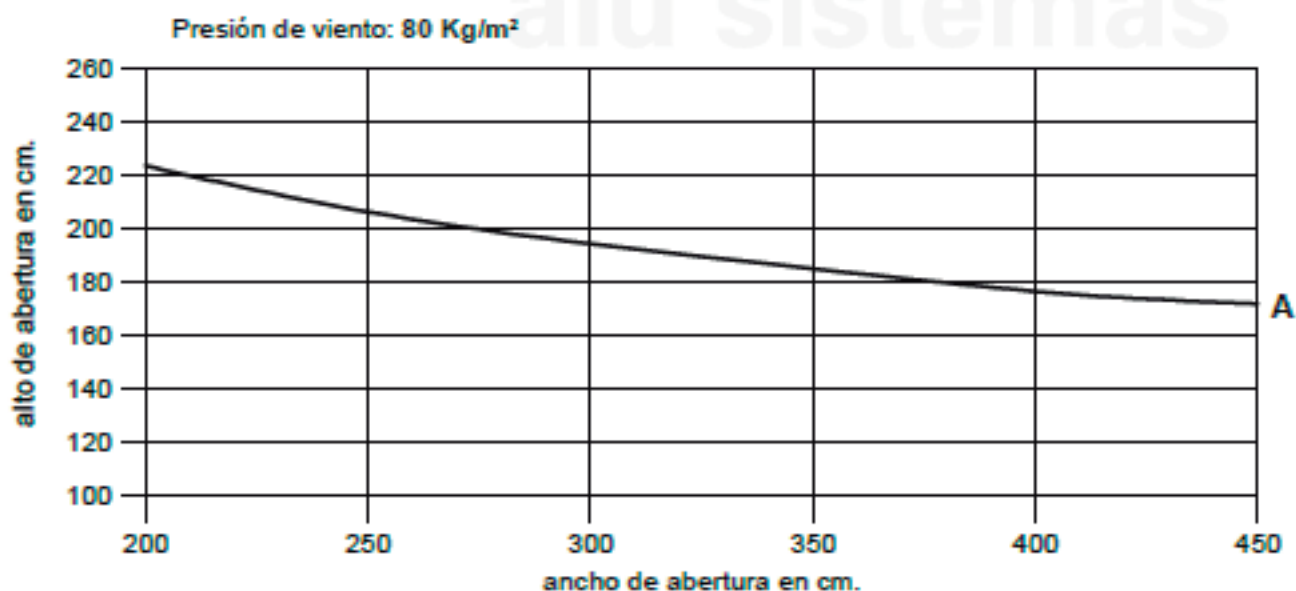
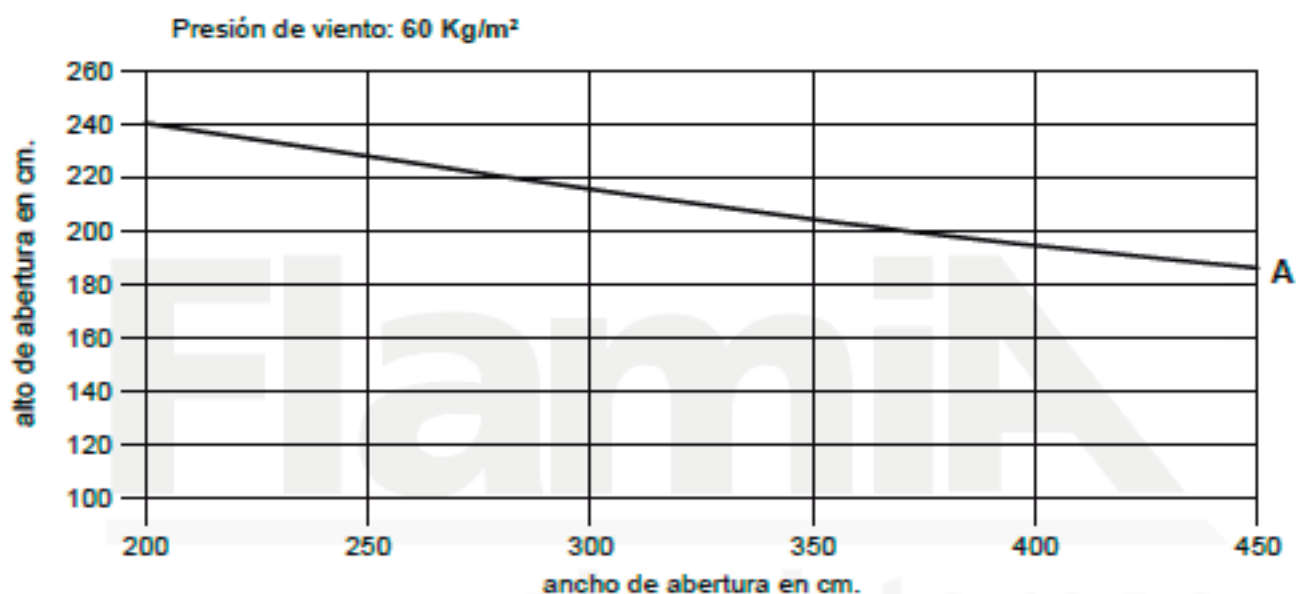

Los tamaños de hoja por debajo de la curva para cada caso cubren las necesidades estáticas. Además de verificar las dimensiones máximas para cada abertura, es necesario calcular el peso de la hoja según el vidrio seleccionado, para saber la limitación del rodamiento a usar. Estos cálculos están realizados en forma teórica (no sustituyen a los cálculos estructurales para cada obra), basándose en la norma IRAM 11507-1, utilizando doble vidriado hermético y una flexión máxima de  $L/300$  con un máximo de 8 mm ( $L =$  Alto de abertura).



## Dimensiones máximas para ventana corrediza

A) 14270 + 14271

$J_{xx} = 49.7 \text{ cm}^4$

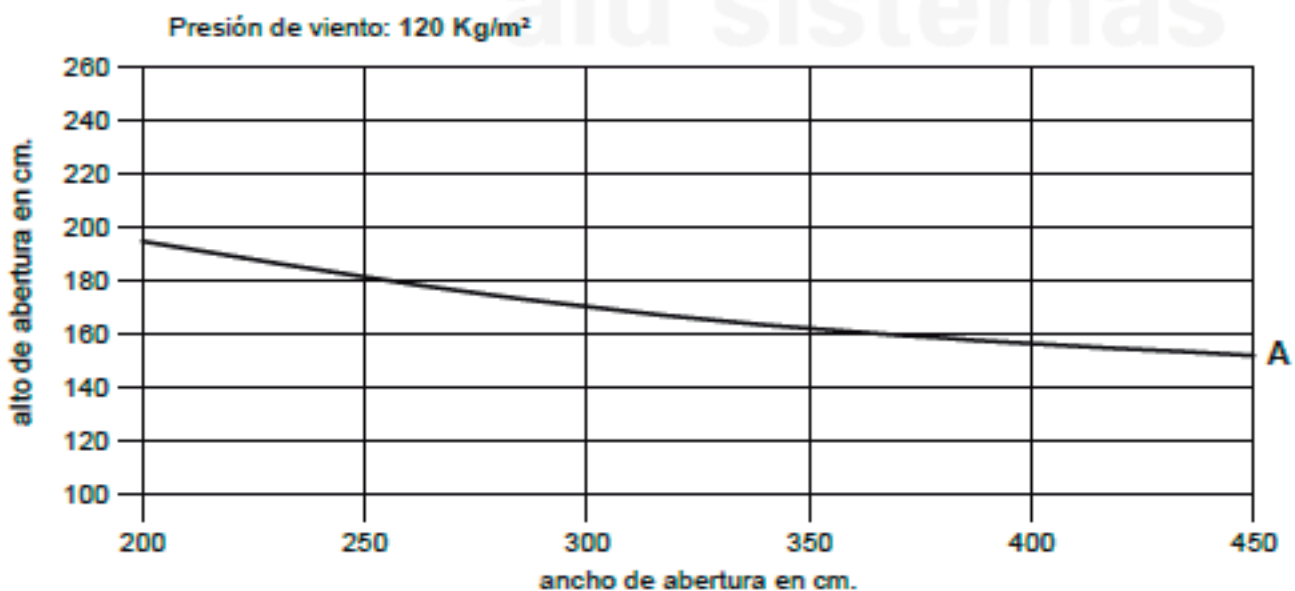
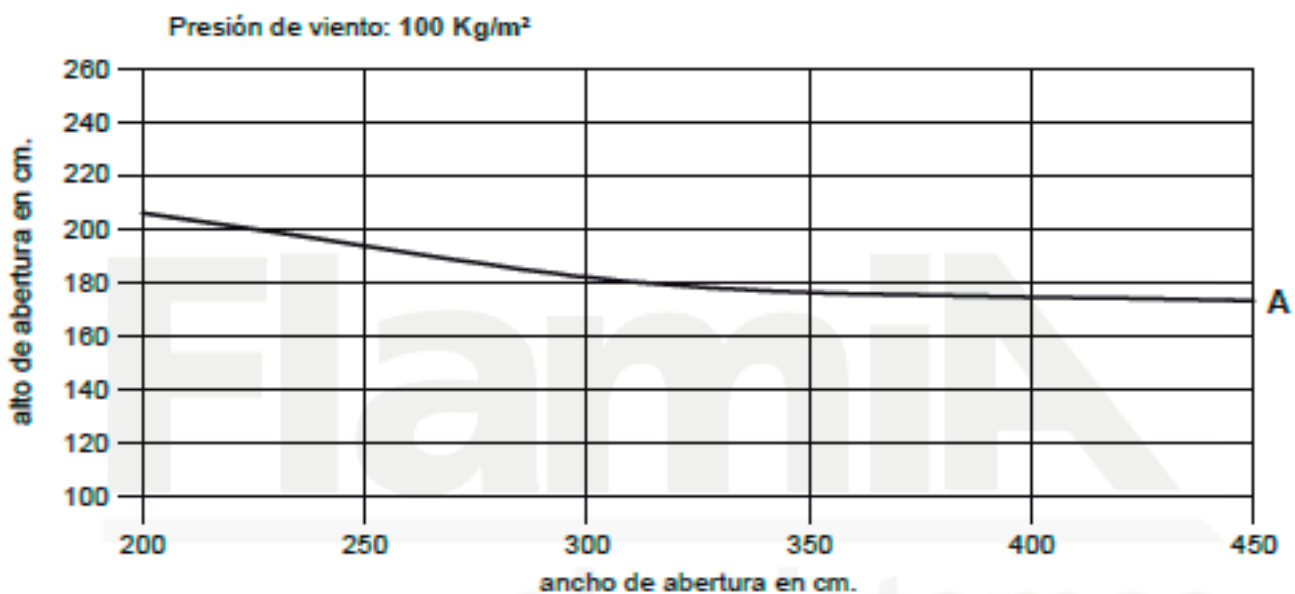

Los tamaños de hoja por debajo de la curva para cada caso cubren las necesidades estáticas.

Además de verificar las dimensiones máximas para cada abertura, es necesario calcular el peso de la hoja según el vidrio seleccionado, para saber la limitación del rodamiento a usar.

Estos cálculos están realizados en forma teórica (no sustituyen a los cálculos estructurales para cada obra), basándose en la norma IRAM 11507-1, utilizando doble vidriado hermético y una flexión máxima de  $L/300$  con un máximo de 8 mm ( $L =$  Alto de abertura).

## Dimensiones máximas para ventana corrediza

A) 14270 + 14271

$J_{xx} = 49.7 \text{ cm}^4$

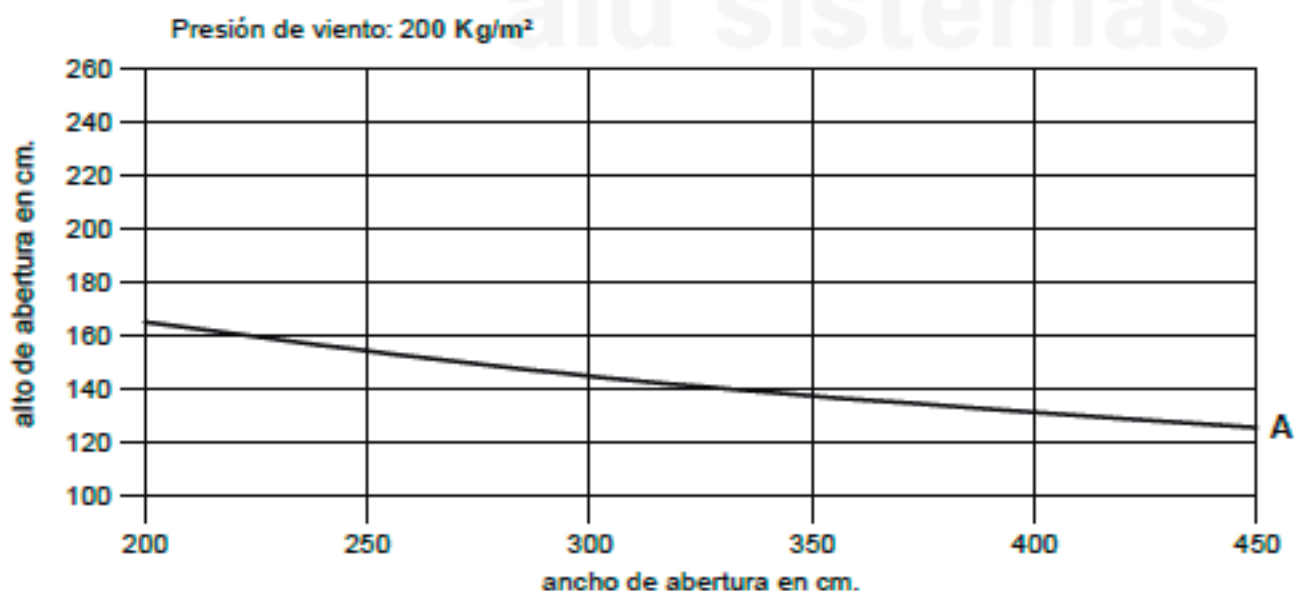
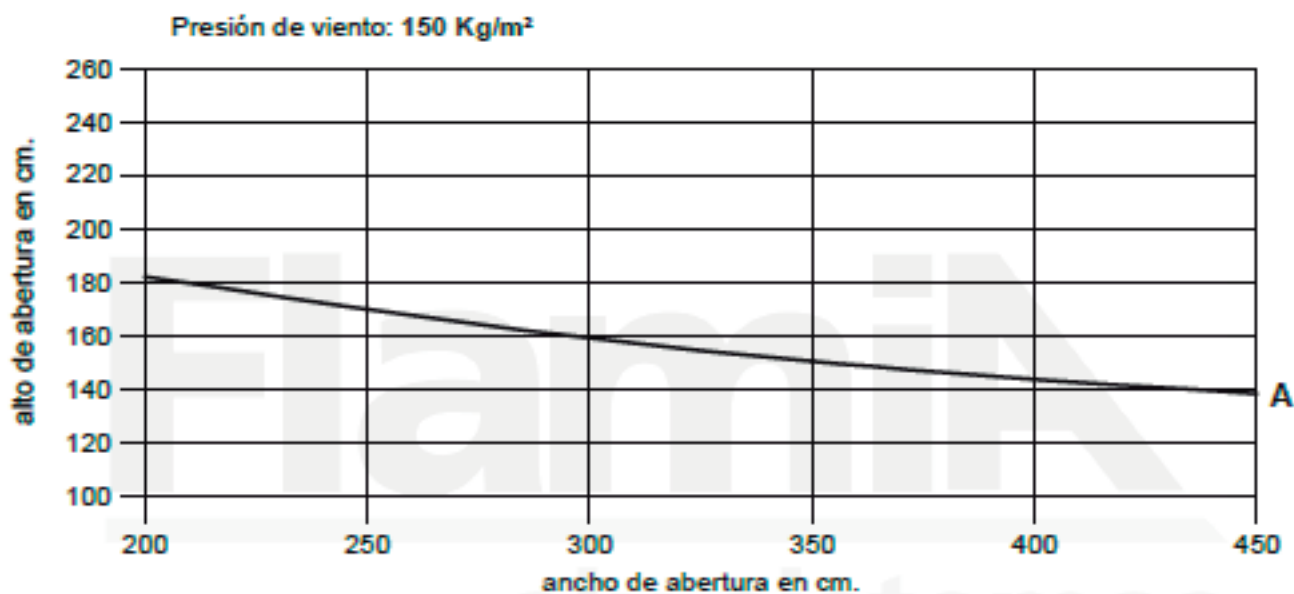

Los tamaños de hoja por debajo de la curva para cada caso cubren las necesidades estáticas.

Además de verificar las dimensiones máximas para cada abertura, es necesario calcular el peso de la hoja según el vidrio seleccionado, para saber la limitación del rodamiento a usar.

Estos cálculos están realizados en forma teórica (no sustituyen a los cálculos estructurales para cada obra), basándose en la norma IRAM 11507-1, utilizando doble vidriado hermético y una flexión máxima de  $L/300$  con un máximo de 8 mm ( $L =$  Alto de abertura).